

GK32700

INSTRUCTION BOOK // PARTS CATALOGUE

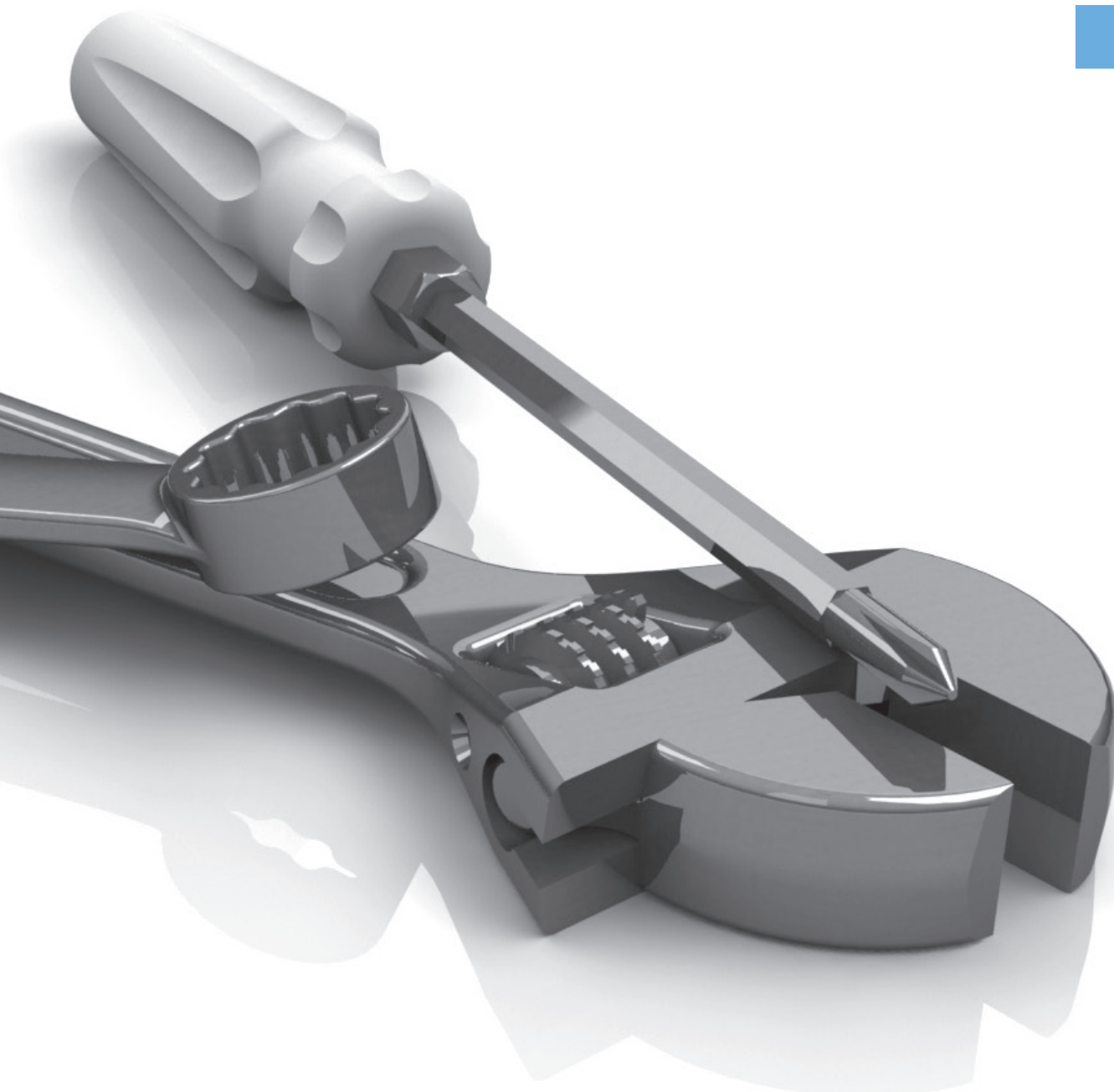

HIGH-SPEED CYLINDER-BED
INTERLOCK SEWING MACHINE



TYPICAL

1. Specifications

- Description.....Super high speed cylinder bed 2 or 3 needle interlock machine.
- Dimensions..... 475 (Length) × 220 (Width) × 405 (Height) mm
- Circumference of Cylinder Bed..... 280 mm
- Weight.....39 kg
- Stitch Type.....ISO 406, 407, 602, 605
- Application.....General seaming of knitted material
- Sewing Speed.....Max. 6,000 stitch/min
(4,500 stitch/min for the machine with Puller)
- Stitch Length.....1.4 ~ 3.6 mm
stitch number: 7 ~ 18 stitch/inch
8 ~ 21 stitch/30 mm
- Needle to be used.....Schmetz or Organ UY128GAS #65 ~ #90
- Needle Distance.....for 2 needle : 3.2, 4.0, 4.8, 5.6, 6.4mm
for 3 needle : 5.6, 6.4mm
- Needle Stroke.....31mm
- Presser Foot Lift.....Max. 7.0mm
(5.0mm for machine with top cover thread)
- Feed Regulation.....by push – button
- Differential Ratio.....Max. normal differential ratio : 1: 2.9
Max. reverse differential ratio : 1: 0.3
- Differential feed regulation..... by adjusting screw or by control lever
(Adjusting during operation from outside
is possible by moving Control Lever up and down.)
- Lubrication.....Automatic lubrication by Oil Pump
(combined use with splashing lubrication)
- Lubrication oil.....YAMATO SF OIL or TERESSO 46
- Capacity of Oil Reservoir ... 1, 000 cc

2. Installation

2.1 Drawing of Table Top Cut – out

* Table Top Installation (Type A: standard)

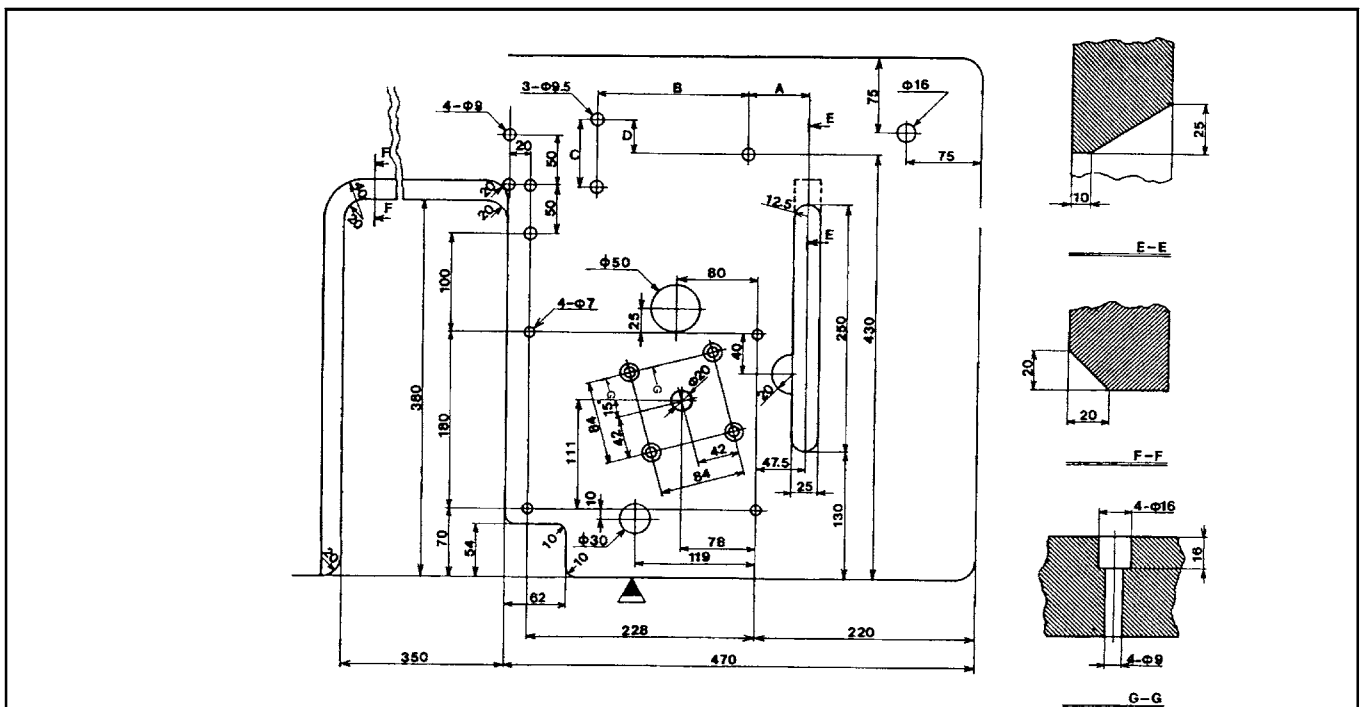

* Table Top Installation (Type B)

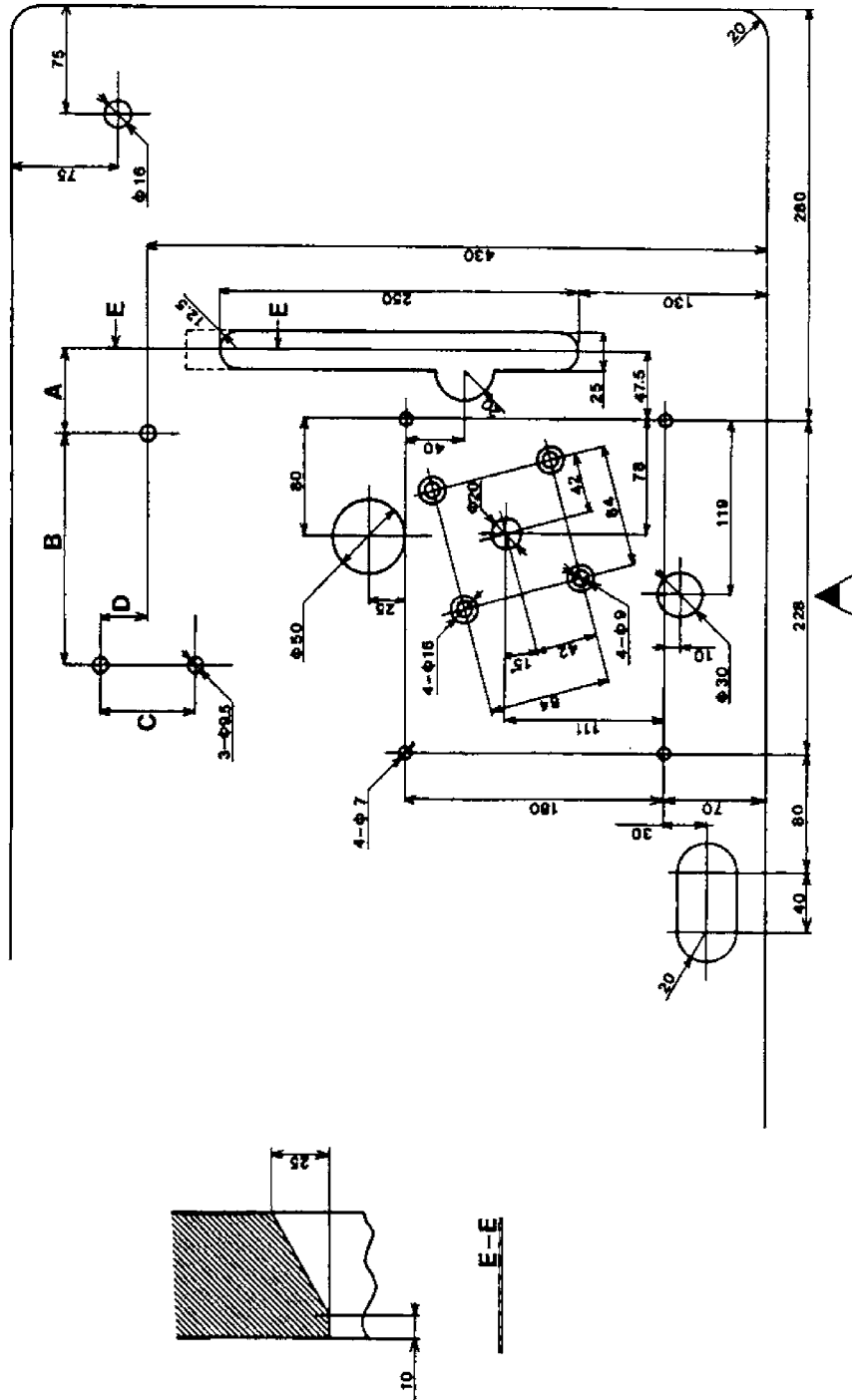

* Semi-submerged Installation

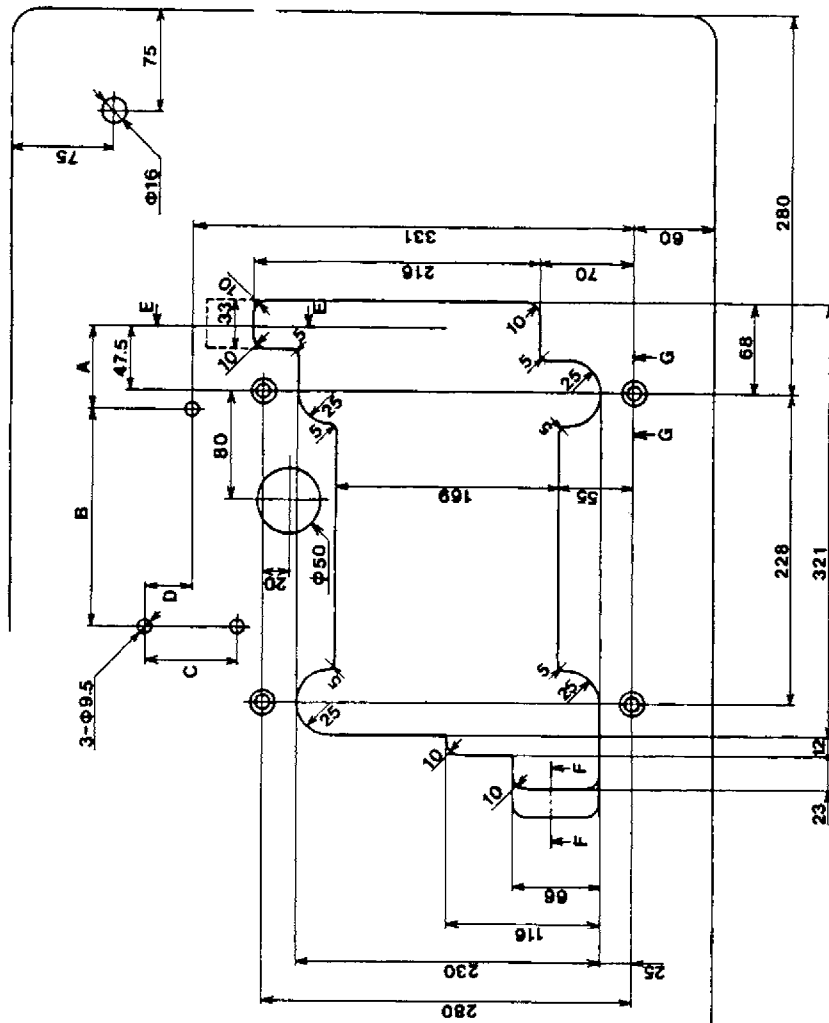
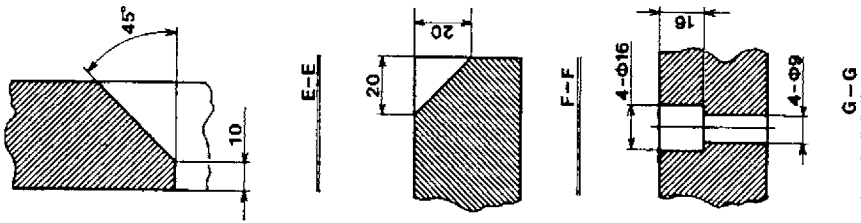

2.2 Table Top Installation

Install the machine correctly referring to the illustration.

Set Bolts and Nuts to Machine Table and put Rubber Cushions on –Bolts and rest the machine on them securely.

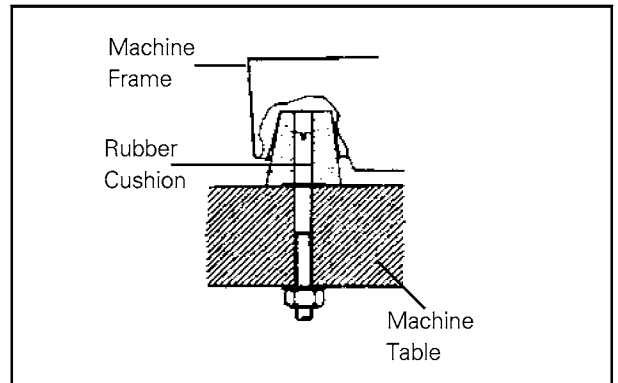

2.3 Semi – submerged

Install the machine correctly referring to the illustration.

Set Screws on Supporting Board and set Supporting Board on Machine Table. Then put Rubber Cushions on Screws on which rest the machine securely.

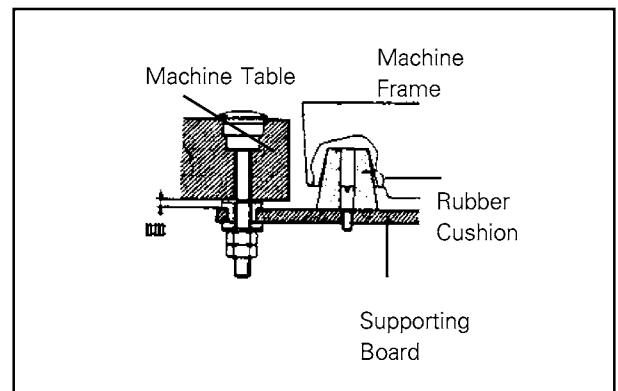

2.4 Installing Belt Cover

Install Belt Cover as shown in the illustration.

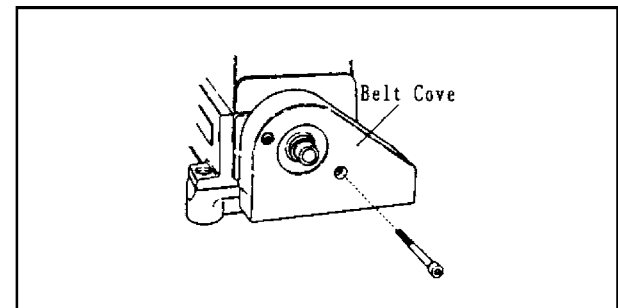

3. Sewing Speed and Rotating Direction of Pulley

The maximum sewing speed of this machine is 6,000 s. p. m. , and ordinary speed is 5, 500 s. p. m. (For the machine with Puller, the max. speed is 4, 500 s. p. m. and ordinary speed is 4, 000 s. p. m.) When operating new machine, it is recommended for the durability to operate at the speed of 5, 000 s. p. m. for the initial 200 hours (about 1 month) then operate at the ordinary speed.

The rotating direction of Pulley (A) is clockwise like Handwheel (B) as shown in the illustration.

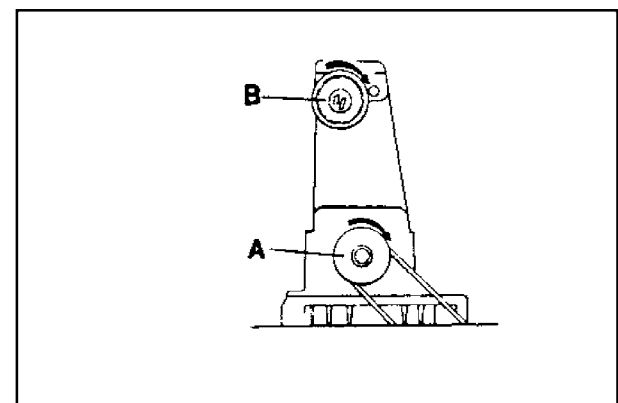

4. Motor and Belt

Use a clutch motor of 3-phase, 2-pole, 400 w (1/2 HP) and a V-Belt of M-type.

Fix the position of motor so that the centers of Motor Pulley shifted to the left by treading Pedal.

dia. of Motor pulley(mm)	s. p. m. of machine	
	50Hz	60Hz
75		4.000
80		4.200
85		4.500
90	4.000	5.000
100	4.500	5.500
110	5.000	6.000
120	5.500	
130	6.000	

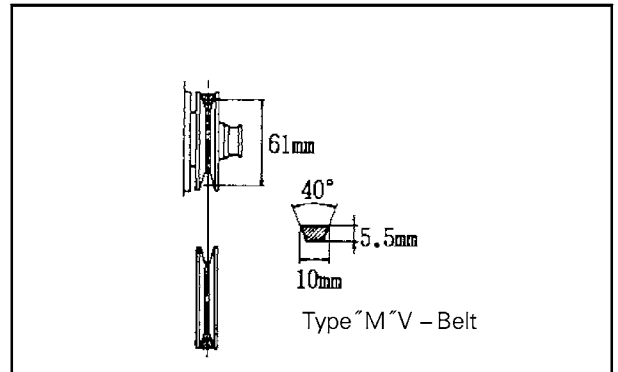

* As the diameters of pulley available on general market is intervals of 5mm, the diameters shown in the above table is the nearest to the calculated value.

5. Lubrication Oil

5.1 Lubricating Oil

Use sewing machine oil No. 18

5.2 Feeding Oil

As the oil in the machine is drained completely at the time of shipment, replenish oil to the upper line of Oil Sight Gauge (C) by removing Seal Plug (A) indicated "OIL" before operating the machine without fail.

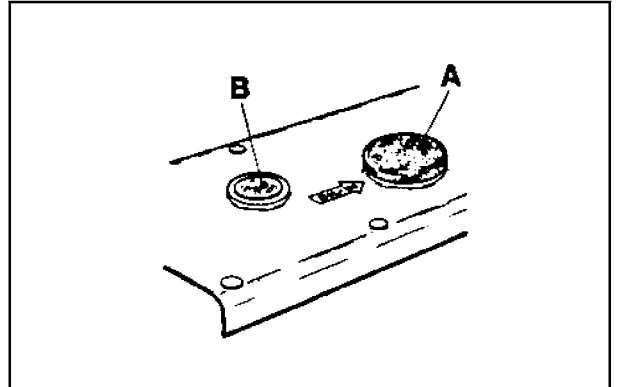

5.3 Oil Sight Gauge and Nozzle

Check Oil Sight Gauge (C) before operating machine everyday. If the oil surface is below the two lines, supply oil.

Make sure that oil flows out of Nozzle(B) at the start of operation.

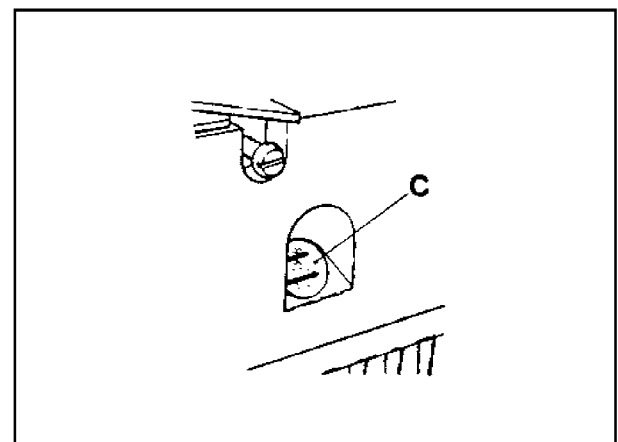

5.4 Oil Change

For the long life of machine, change lubrication oil completely after 250 hours of initial operation. Oil change should be made following the next procedure.

① After removing V-Belt from Motor Pulley, remove Machine Head out of Machine Table.

② Remove Screw (D) and drain oil. At this time, be careful not to smear V-Belt.

③ After draining, tighten Screw (D) without fail.

④ When replenishing oil, refer to para "5 ~ 2 Feeding Oil".

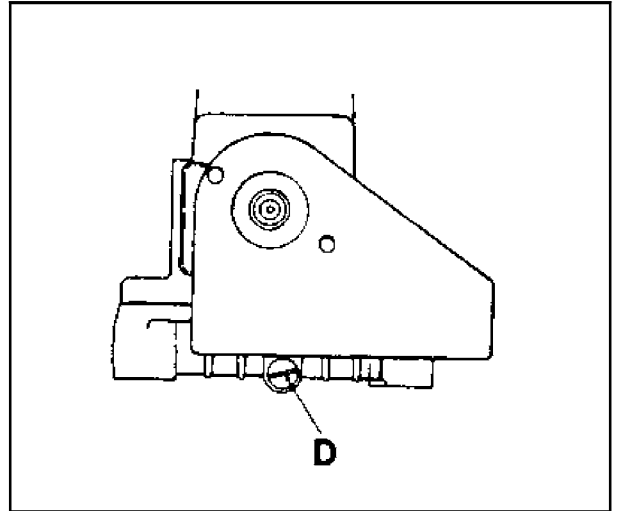

5.5 Changing and Replacing Oil Filter

When Oil Filter (E) is clogged with dust, proper lubrication is not possible. Generally check Oil Filter once every six months.

And, when no or very little oil comes out of Nozzle though enough oil is in Oil Reservoir, check Oil Filter.

To check Oil Filter, remove Oil Filter Cap (F). If it is clogged with dust, renew it.

Note : When removing Oil Filter Cap, take care not to spill oil sticking to Oil Filter.

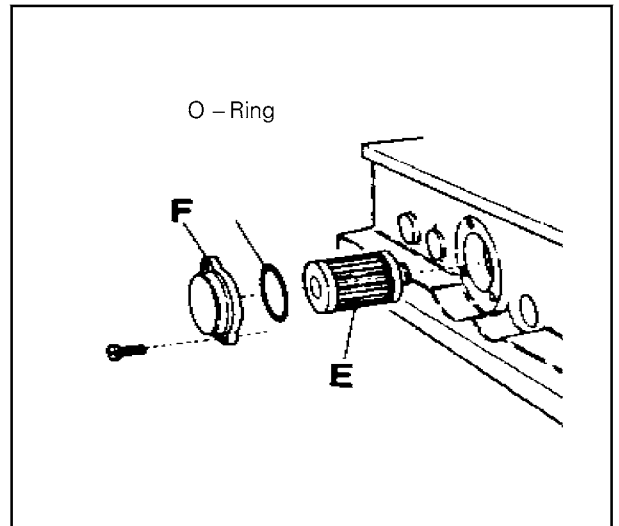

5.6 Cleaning the Machine

Every day after operation, clean the machine to remove dust and thread chips inside.

The cleaning should be made by opening Side Cover and front cover and by using air gun and the like. Remove rubber Seal Plug (G) behind the machine and remove dusts and others around Oil Filter Screen using tweezers and air gun once a week or two.

When Oil Filter Screen is clogged, oil around Feed Bar dose not return to Oil Reservoir, resulting in splashing of oil by Looper Thread Take-up.

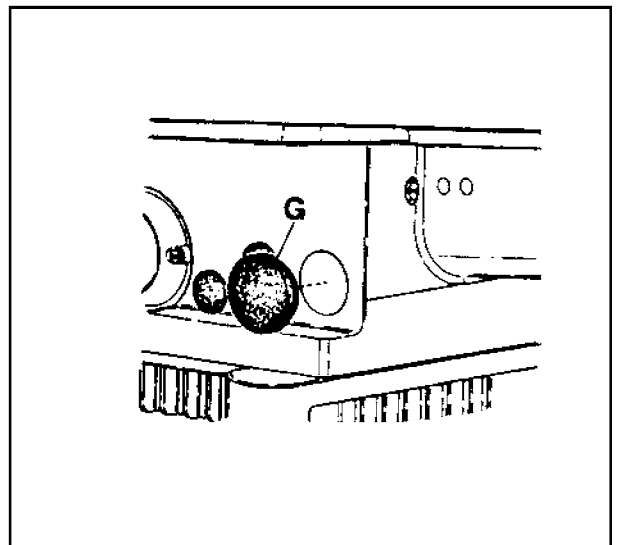

6. Proper Operation

6.1 Needles to be used and the Installation

Needle UY128GAS of Schmetz or Organ is to be used. There are many sizes of needle, and the most suited needle to the thickness and the kind of material should be selected.

Replacing needle should be made correctly with the scarf facing rightly backward as shown in the illustration.

japanese size	9	10	11	12	13	14
Metric size	65	70	75	80	85	90

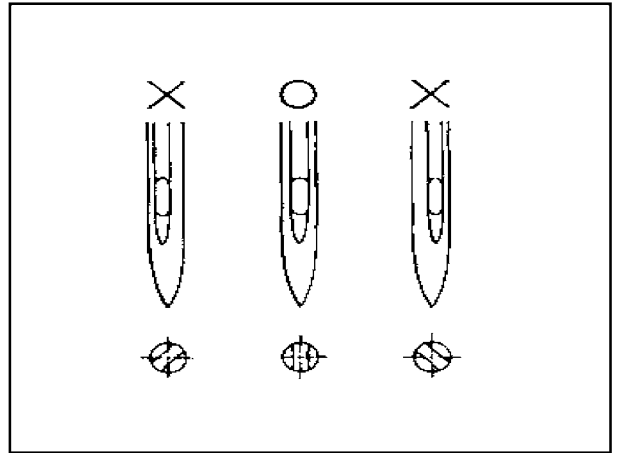

6.2 Threading

Threading should be made correctly referring to the illustration.

Improper threading might cause skip stitch, thread breakage and uneven tension.

A, B, C ... needle thread D ... top cover thread E ... longer thread. The threading for three needle machine is shown in the illustration below. For two needle machine, threading is the same except two needle thread. Easy threading is possible with the lifting up of Supporting Plate by pressing Lever (F).

After threading, return it back to the original position by pressing part (G) without fail.

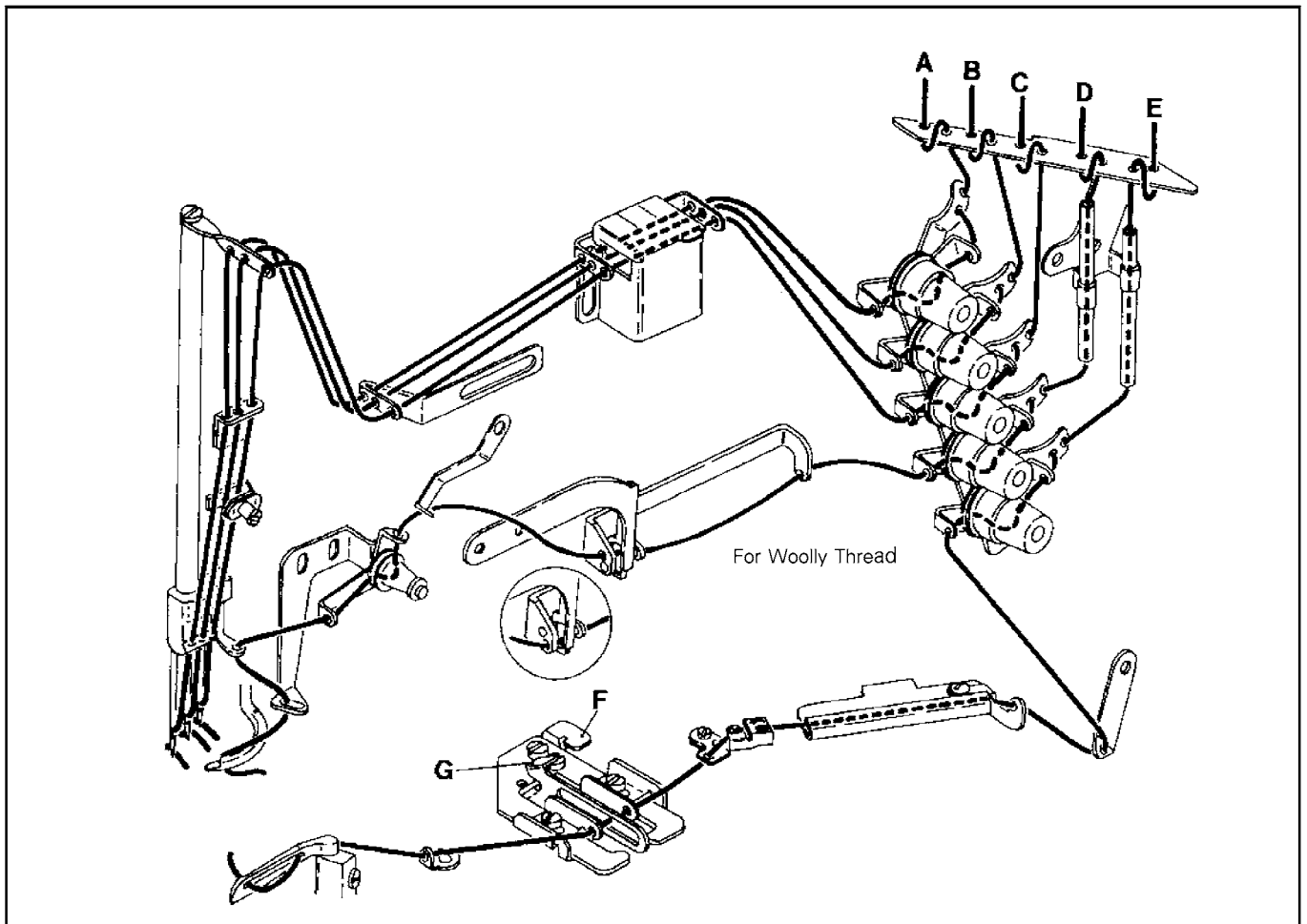

6.3 Pressure of Presser Foot

To increase the pressure of Presser Foot, turn Adjusting Screw (B) clockwise after loosening lock Nut(A) and to decrease turn it counterclockwise.

Pressure of Presser Foot should be as weak as possible so long as Presser Foot can operate properly.

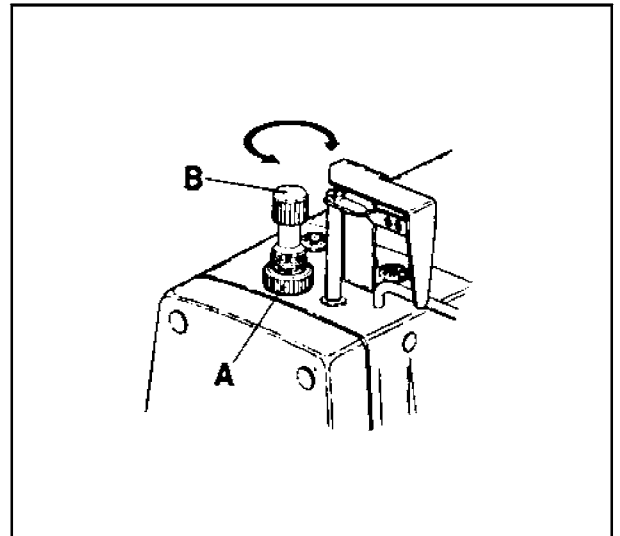

6.4 Adjusting Presser Foot

Adjust the right/left position of needle drop point of Presser Foot (C) to the center by loosening Screw (D) and moving the tip of Presser Foot left and right.

After the adjustment, tighten Screw (D).

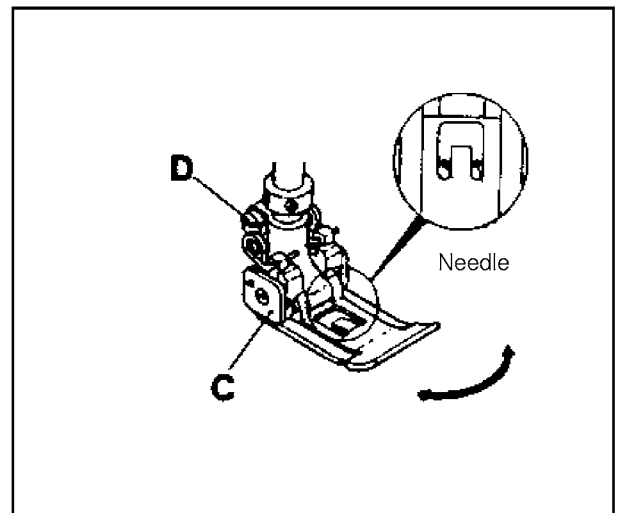

6.5 Adjusting Stitch Length

Adjustment of stitch length can be made steplessly from 1.4mm to 3.6mm.

The table below shows the stitch length, stitch number per inch (25.4mm) and stitch number per 30mm.

stitch length (mm)	stitch number (per inch)	stitch number (per 30mm)
3.6	7	8
2.4	10.5	12.5
1.4	18	21

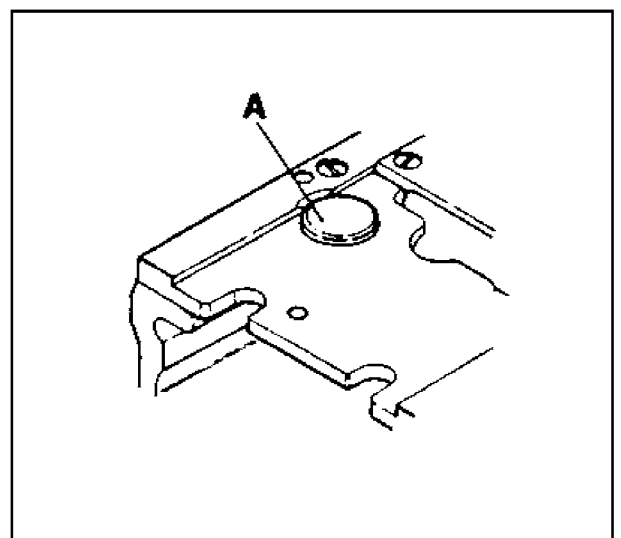

* Change of stitch length

Press Push Button (A) with left hand lightly till the tip of which contact to a part inside.

Keep pressing, turn Handwheel with right hand till Push Button gets in. At this point, press in Push Button strongly and turn Handwheel.

A graduation on the circumference of Handwheel indicates a stitch length (mm), which should be aligned with the Mark (B), then release hand.

Note : In case of machine with UT Device (Lower Thread Trimmer) which is equipped with a motor with Automatic Needle Positioning System, Motor Switch must be turned off without fail when changing stitch length.

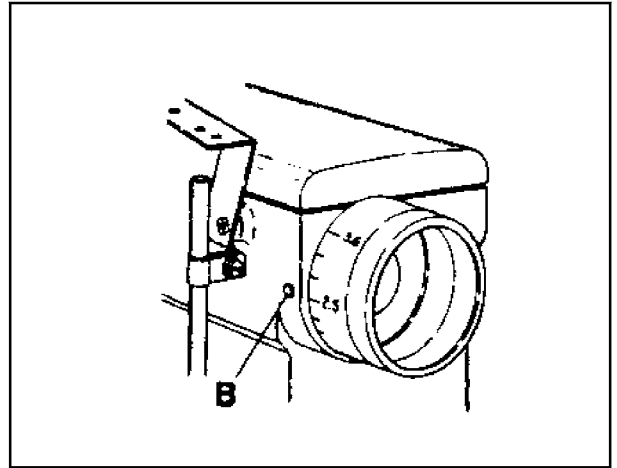

6.6 Adjusting Differential Feed

Normal differential feed or reverse differential feed can be set freely by turning Knob (C).

As differential feed and main feed is driven individually, when main feed amount (stitch length) is changed, the differential ratio changes accordingly. In this case readjustment is necessary.

The graduation shows the amount of differential feed. For instance, in case the desired feed amount (stitch length) is "2" and if the graduation is set at "2" by turning Knob (C), the differential ratio becomes 1 : 1.

When setting the graduation over "2", it becomes normal differential and setting it under "2", it becomes reverse differential.

For the main feed amount the upper limit is "4".

* When using Differential Feed Control Lever.

Fix Differential Feed Control Lever at the desired position with Nut (E) within the range from the position of graduation on Lever when turning Knob (C) to Stopper (D).

At the time of using max. differential feed, turn Knob (C) and set Lever at graduation "1". For adjusting feed amount during operation, attach a chain to the Lever.

※ The range of differential ratio varies according to the stitch length. Refer to the table below range differential

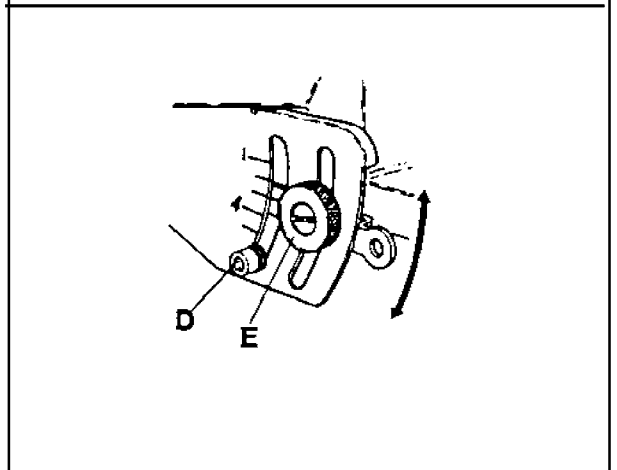
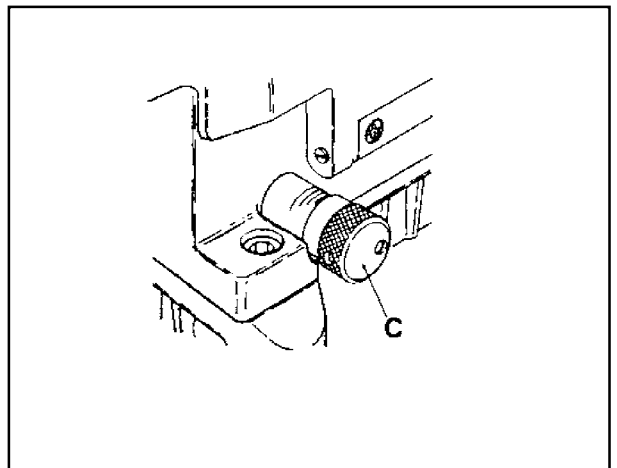

stitch length	max. normal differential	max. reverse differential
3.6	1: 1.1	1: 0.3
2.5	1: 1.6	1: 0.4
2.0	1: 2	1: 0.5
1.4	1: 2.9	1: 0.7

6.7 HR Device and SP Device

Sometimes heat generated on the needle by the friction with the material at high speed operation causes such troubles as thread breakage, skip stitch and widening of stitch hole especially when using synthetic threads and fabrics.

To reduce these troubles, HR Device (needle point cooling) and SP Device (needle thread oiling) are the standard equipment for this machine.

Using oil of silicone system is most effective.

Note 1: Open Lid (A) of HR Container and Lid (B) of SP Container and check the oil. If it is running short, supply it.

Note 2: Though it is recommended to use HR and SP Devices, when they are not used judging from the sewing condition, remove Felt because it might be better for the needle and thread not to touch the dry Felt.

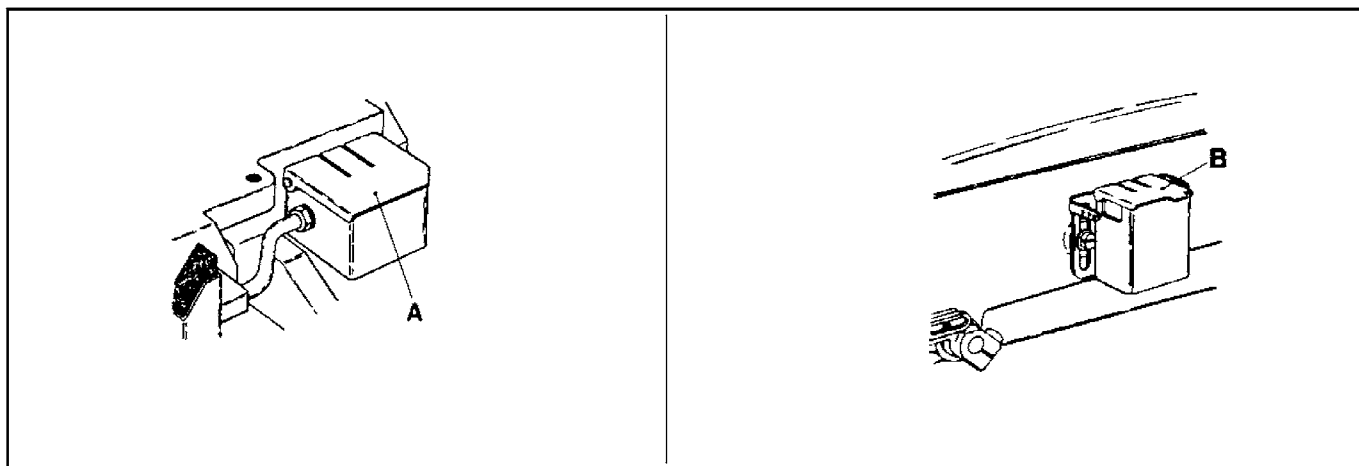

7. Adjustment of Sewing Machine

7.1 Looper Thread Tension

Align Mark (A) of Supporting Plate and thread holes of Thread Eyelet (B) and (C). That is the standard adjustment.

To increase take up amount of looper thread, move Looper Thread Eyelet forward after loosening screws of thread eyelet (B) and (C), and to decrease move them backward.

Note: Too much take up amount of looper thread will cause skip stitch.

When using wooly thread, move Thread Eyelet (B) and (C) all the way forward and don't pass the thread between Supplementary Tension Discs (D).

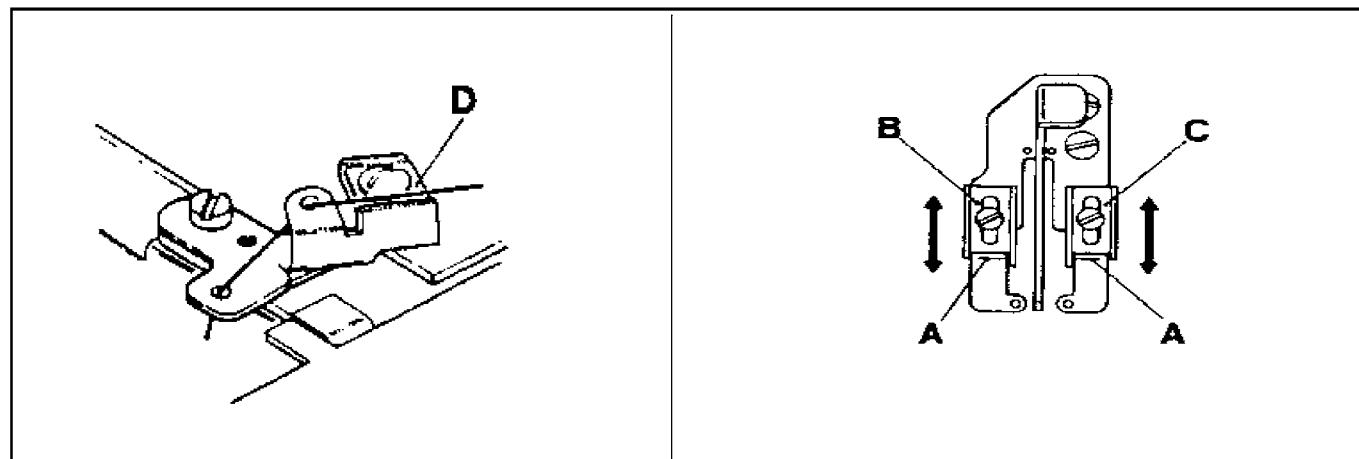

7.2 Needle Thread Tension

It is not so easy to make loop for some kind of thread. This makes it difficult for Looper to catch the needle thread, causing skip stitch. In such a case, pass the needle thread through Supplementary Tension Disc (A) as shown in the illustration.

* In case the formation of needle thread loop is unstable when using stretchable thread like synthetic thread, use Needle Thread Guide. With Needle Bar at the lowest position, the center of thread hole of Needle Bar Thread Eyelet (B) should be even with the surface of Needle Thread Guide (C); and (B) and (C) should be parallel with each other.

That is the standard condition.

The adjustment of the height and left/right position of Needle Thread Guide (C) is made by loosening Screw (D) and moving Needle Thread Guide (C) up and down; and left and right.

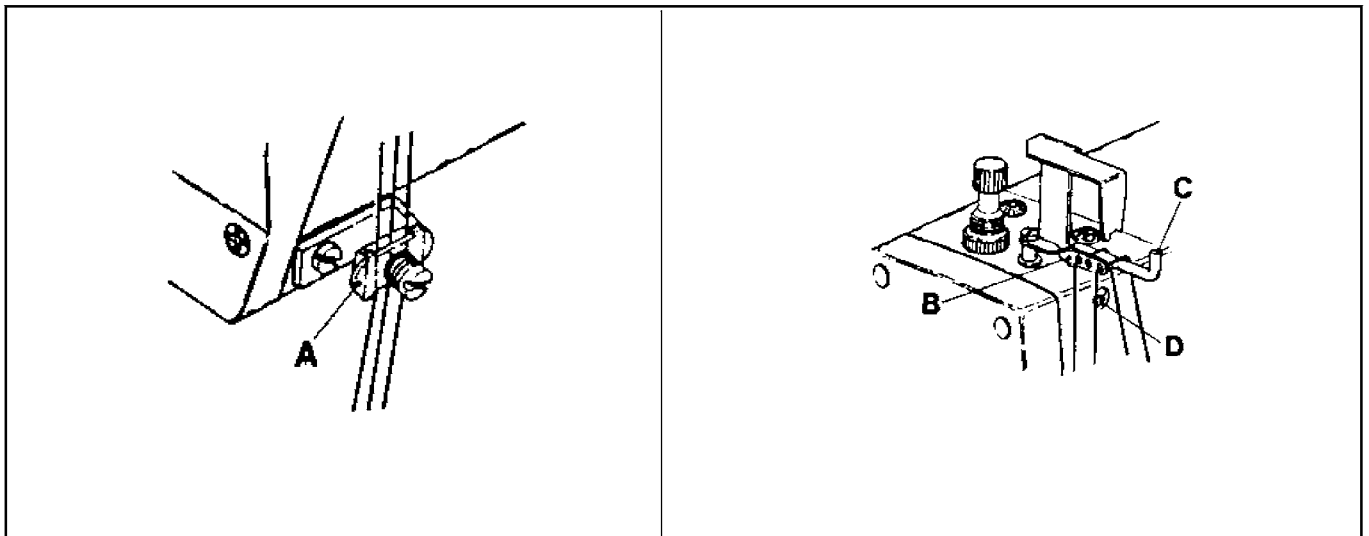

7.3 Needle and Spreader

① Installing Spreader Provide a clearance of 0.5~0.8mm between left needle and the tip of thread hooking part (a) of Spreader (A) when Spreader moves to the left. Give the distance of 4.5~5.5mm from the center of left needle to the thread hooking part (a) when Spreader comes to the extreme left. The height from the surface of Stitch Plate up to the undersurface of Spreader (A) should be 8.5~9.5mm. The adjustment is made by loosening Screw (B) of Spreader and Screw (C) of Spreader Holder.

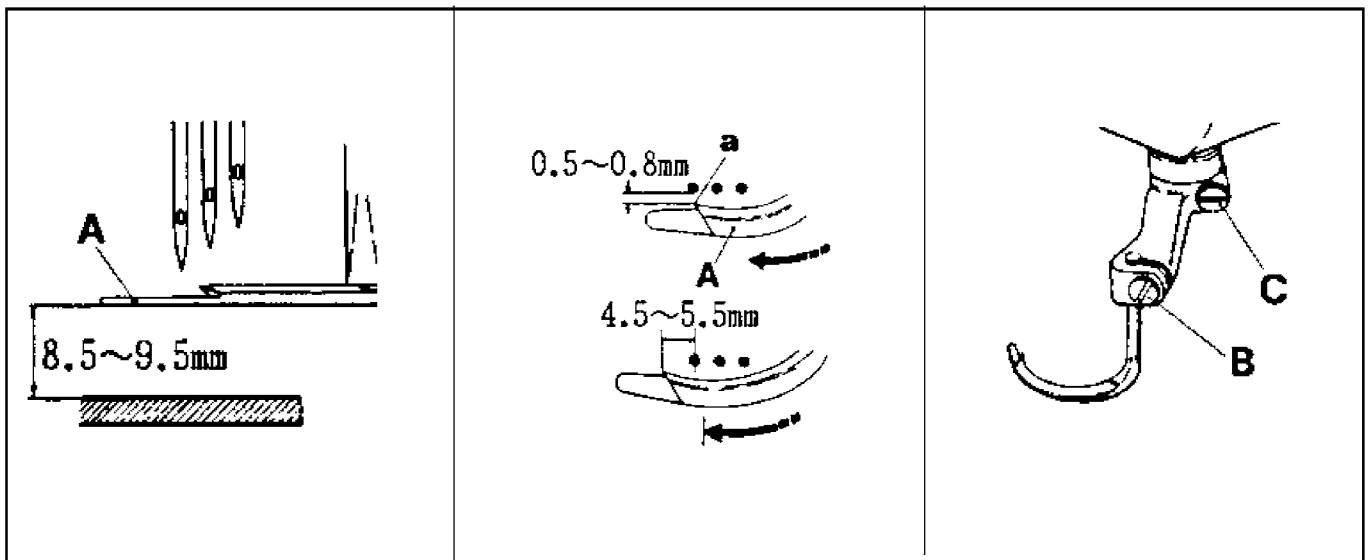

② Installing Top Cover Thread Guide.

Provide a clearance of 0.5mm between under surface of Top Cover Thread Guide (D) and the surface of Spreader (A) and tighten Screw (E) so that the thread is caught by thread hooking park properly when Spreader comes to the extreme right.

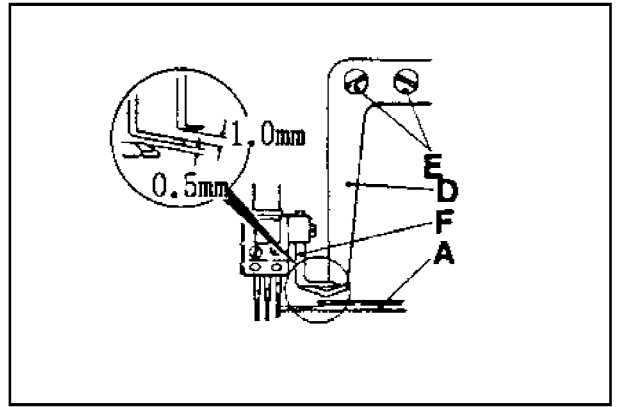

③ Installing Top Cover Thread Eyelet

When Needle Bar at the lowest position, provide a clearance of 1.0mm between the surface of Top Cover Thread Guide (D) and the undersurface of Top Cover Thread Eyelet (F). And set the thread hole of Top Cover Thread Eyelet (F) on the center line of slot of Top Cover Thread Guide (D). then tighten Screw (G).

* Adjustment ①, ②, and ③ should be made according to the thread to be used.

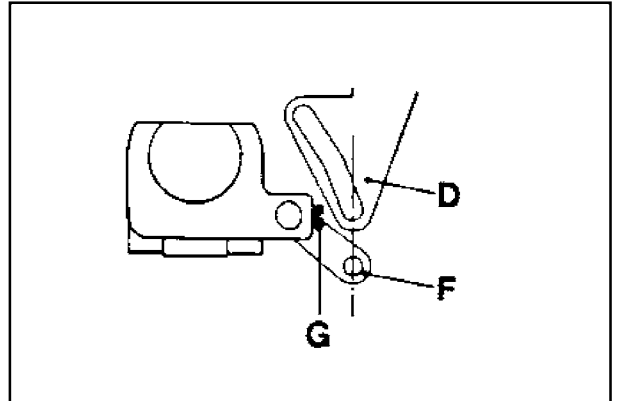

7.4 Adjusting Feed Amount of Puller (In case of machine with Puller Mechanism)

The adjustment procedure of feed amount is as follows:

- ① Remove Seal Plug (A) on Top Cover.
- ② Turn Handwheel till Screw (B) of Feed Roller Eccentric appears, then loosen Screw (B).
- ③ Turn Handwheel till Adjusting Screw (C) appears at the hole of Seal Plug.
- ④ To increase the feed amount, turn Adjusting Screw (C) counterclockwise and to decrease turn it clockwise.
- ⑤ Tighten Screw (B) of Feed Roller Eccentric. Use a Hexagonal Screwdriver in the accessory box. (Tightening torqu: 25kgf. cm .)

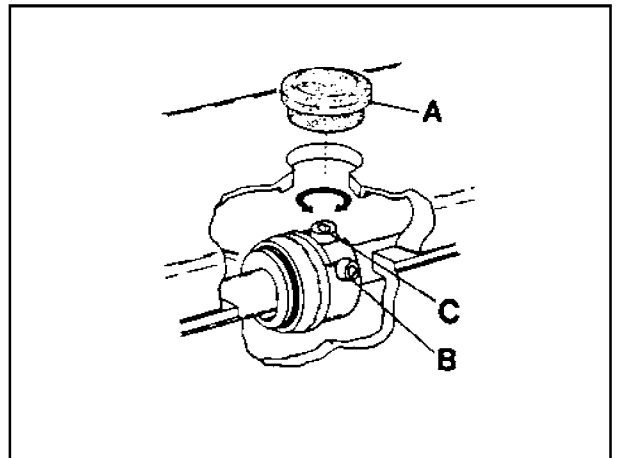

7.5 Pressure of Upper Feed Roller

The pressure should be the least necessary for feeding fabric between Upper and Lower Feed Roller. To increase the pressure, turn Adjusting Screw (D) Clockwise and to decrease, turn it counterclockwise.

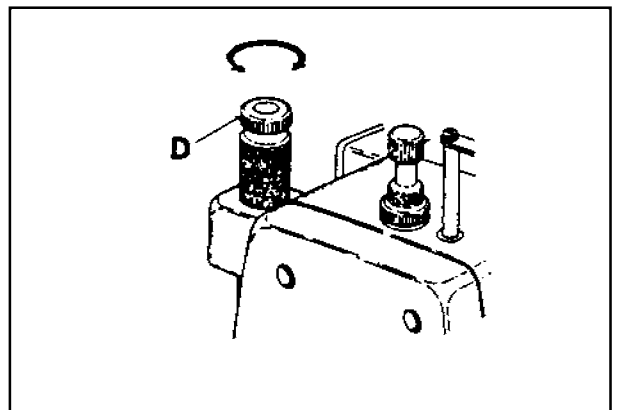

① Looper movement to the right

With Needle at the lowest point and Looper at the extreme right, the distance from the tip of Looper to the center of right needle varies according to the needle distance and should be adjusted referring to the value shown below. The adjustment is made by loosening Screw (A) of Looper Holder.

※ For any needle distance the distance from the center of Needle Bar to the tip of Looper is 6.0mm.

needle (symbol) distance	looper movement to the right
3.2mm(32)	4.4mm
4.0mm(40)	4.0mm
4.8mm(48)	3.6mm
5.6mm(56)	3.2mm
6.4mm(64)	2.8mm

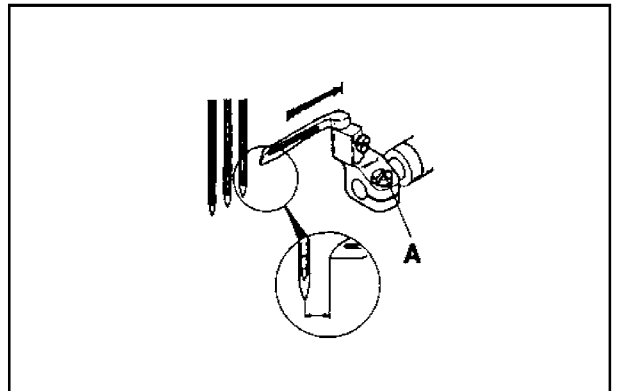

* For easy adjustment of Looper movement to the right, use Timing Gauge (95220). As the Timing Gauge is optional, request it to the agent who sold the machine to you or directly to us.

* Application of Timing Gauge.

Symbol (A, B, C, D, E) for each needle distance are inscribed on Timing Gauge. With Looper at its extreme right, in the condition that the right needle put in the V-groove for desired needle distance, apply the tip of Looper to Timing Gauge, then tighten Screw (A) of Looper Holder.

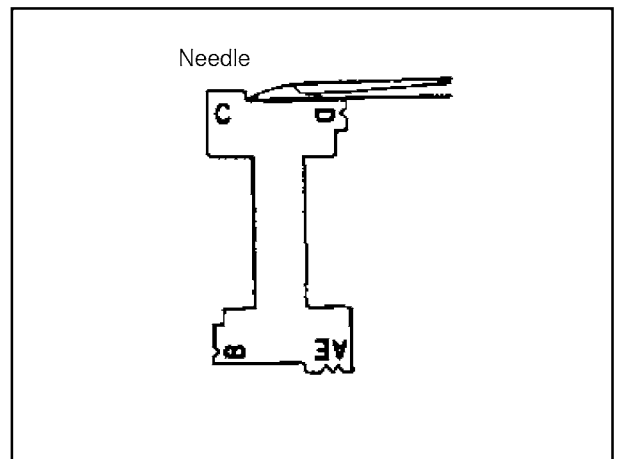

② Needle height

When the tip of Looper comes to the center of left needle, it should pass 0.5~1.0mm over the upper end of needle eye.—That is, needle height is set on the basis of Looper.

Of course needle must be installed into the needle hole of Needle Clamp correctly while Looper must be put all the way into Looper Holder and be tightened securely.

The adjustment of needle height should be made by inserting screwdriver through access hole of Head Cover, loosening Screw (A) of Needle Bar Bracket and moving Needle Bar up and down.

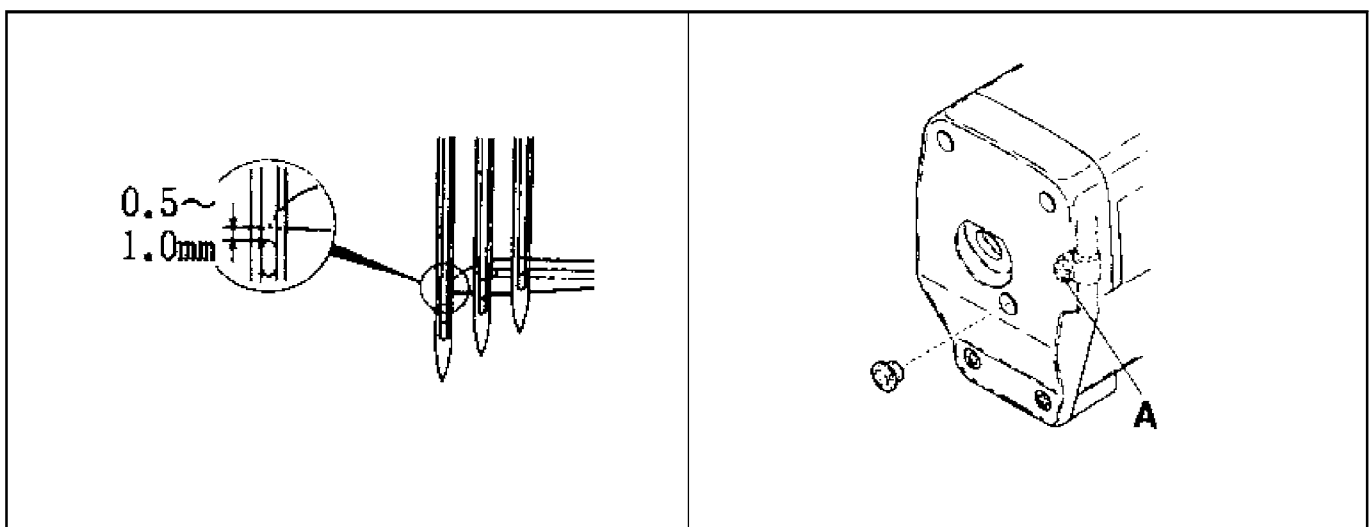

③. Front/Rear position of Needle and Loooper

* For 3-needle: When the tip (A) of Loooper meets the Left Needle (B), clearance between them should be 0.2~0.3mm. The adjustment is made by loosening Screw (D) of Loooper Holder.

* For 2-needle: When tip (A) of Loooper meets the Left Needle (C), clearance between them should be 0.2~0.3mm. The adjustment is made by loosening Screw (D) of Loooper Holder.

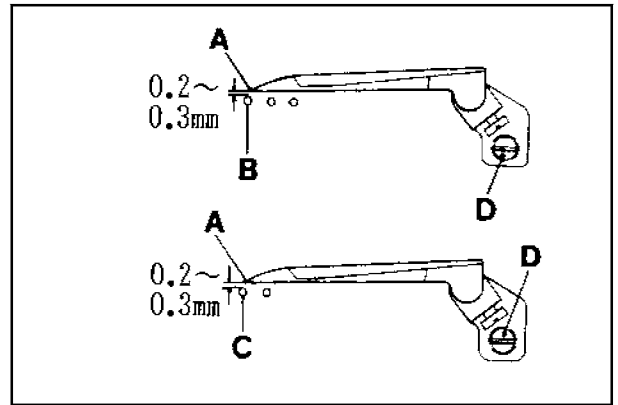

④ Needle and Needle Guard (Rear)

* Height of Needle Guard (Rear) With Needle Bar at the lowest position, align the centers of needles with the line (a) of Needle Guard (Rear) (A).

* Front/Rear position of Needle Guard (Rear) When the tip of Loooper comes to the center of right needle, adjust the clearance between Needle and Loooper to 0~0.5mm by pressing Needle Guard (Rear), At this time, provide a clearance of 0~0.5mm between left needle and Needle Guard (Rear). These adjustments are made by loosening Screw (B) and (C).

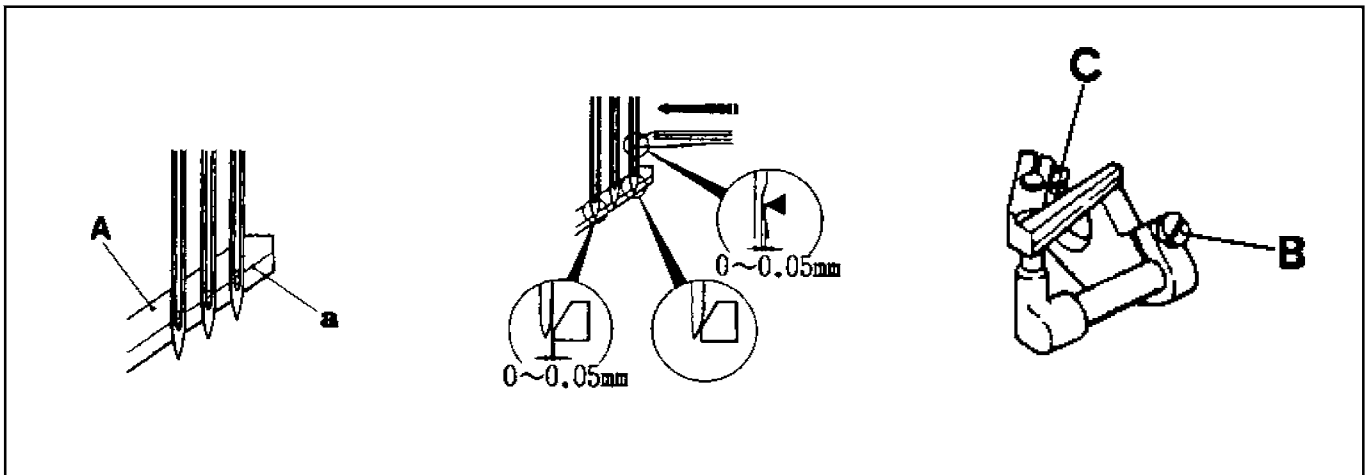

⑤ Needle and Needle Guard (Front)

When the tip of Loooper comes to the center of Left Needle, make it 1.5~2mm higher than the Needle. At this time, provide a clearance of 0~0.3mm between the Needle and Needle Guard (Front) (D).

And when the tip of Loooper is returned to the Right Needle, provide a clearance of 0~0.3mm between the Needle and Needle Guard (Front). These adjustments are made by loosening Screw (E) and (F).

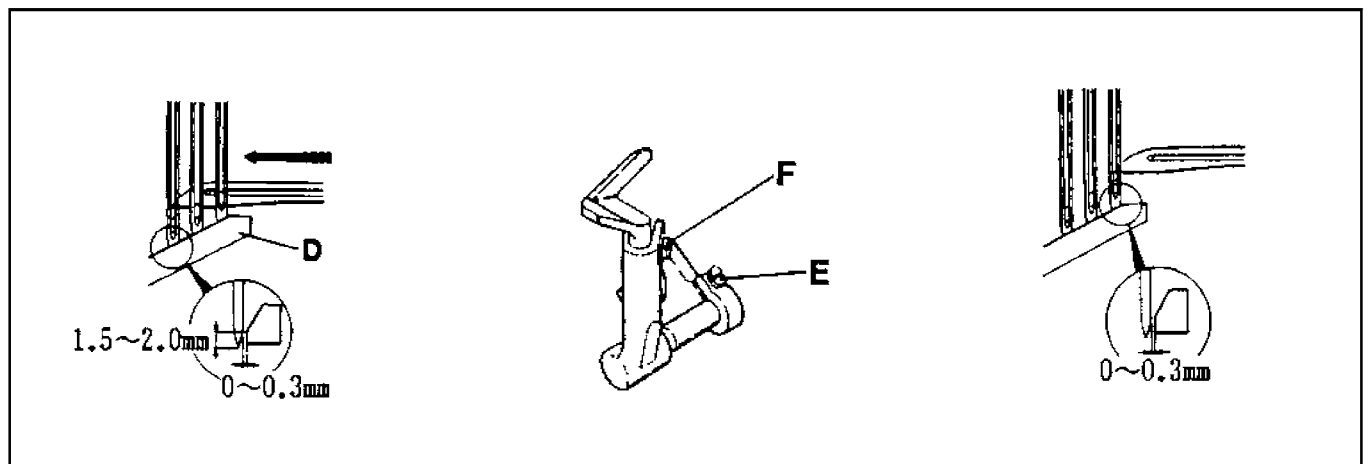

1

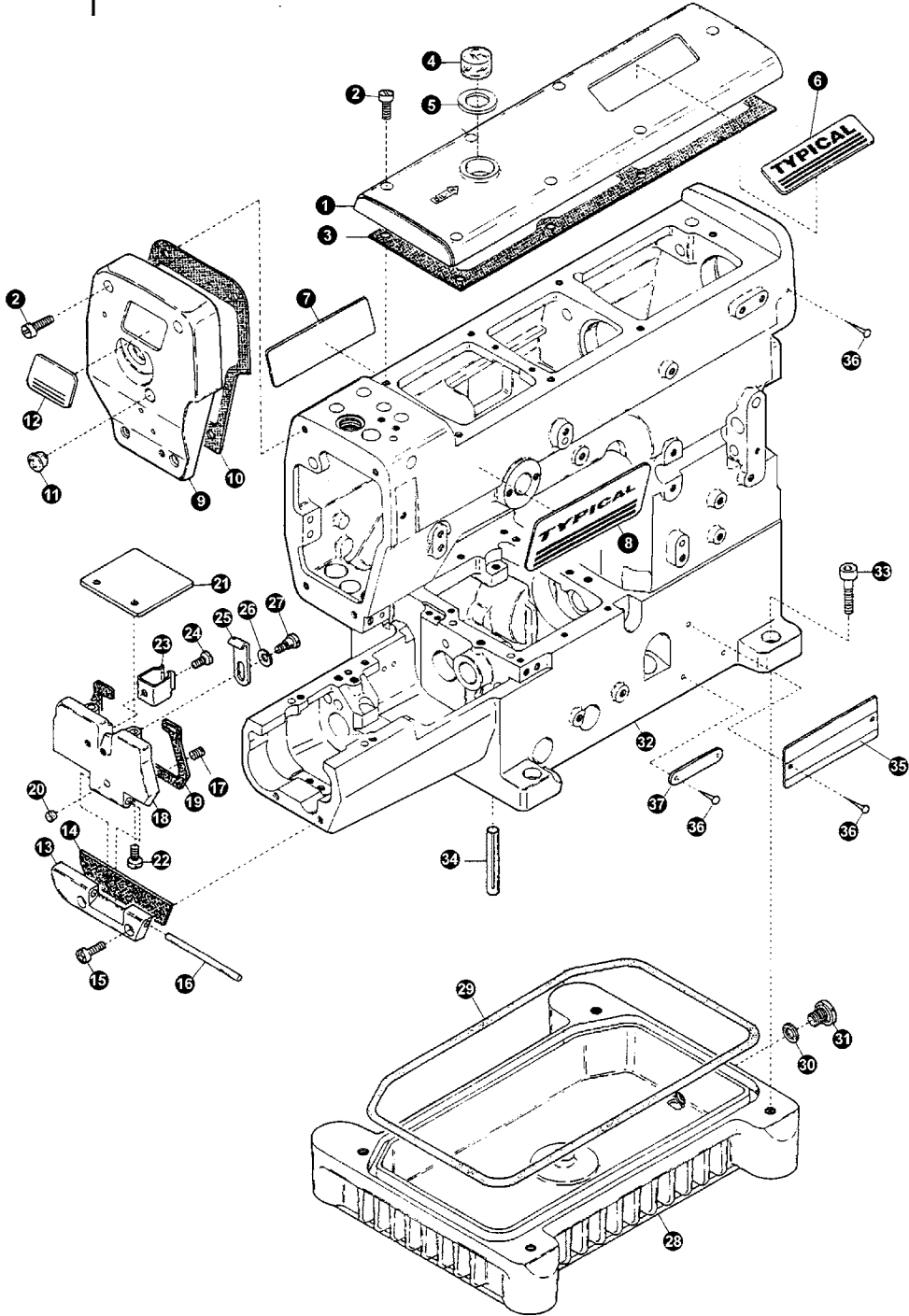

1. MISCELLANEOUS COVERS (1)

No.	Ret. No.	Description	Qt
1	110130001	Top cover	1
2	S150237003	Screw	11
3	110130002	Top cover gasket	1
4	043120002	Oil sight window	1
5	043120003	Oil sight window gasket	1
6	110100021	Brand name plate	1
7	110100023	Brand name plate	1
8	110100022	Brand name plate	1
9	110100001	Head cover	1
10	110100002	head cover gasket	1
11	110100003	Head cover seal plug	1
12	110100020	"T" Emblem	1
13	182100005	Side cover hinge	1
14	182100006	Side cover hinge gasket	1
15	B62401012	Screw	2
16	182100007	Side cover hinge pin	1
17	S150224001	Screw	1
18	182140001	Side cover	1
19	182140002	Side cover gasket	1
20	182140003	Seal plug(rubber)	1
21	182140004	Cloth plate	1
22	B02400812	Screw	2
23	182140005	Cover latch spring	1
24	S150237002	Screw	1
25	182140006	Side cover hook	1
26	142100014	Conical spring washer	1
27	182140007	Screw	1
28	182100008	Oil reservoir	1
29	182100009	Oil reservoir gasket	1
30	182100012	Drain hole seal	1
31	182100013	Screw	1
32	182110000	Machine frame unit	1
33	S150220006	Screw	4
34	182100015	Machine frame supporting bar	4
35	182100016	Model plate(see the below)	1
36	S150340001	Rivet	5
37	182100018	Serial number plate	1

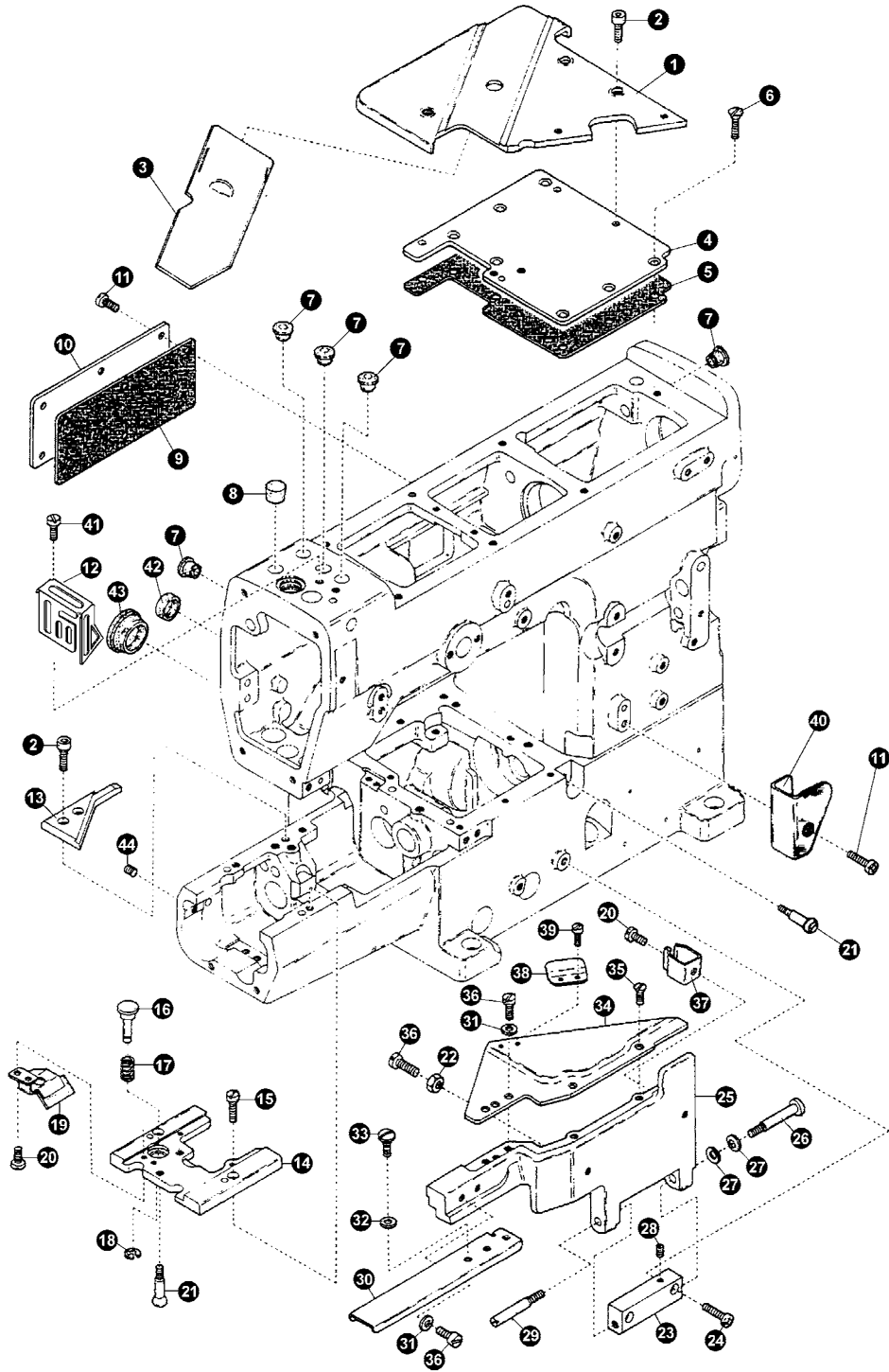

2. MISCELLANEOUS COVERS(2)

No.	Ret. No.	Description	Qt
1	182160000	Cloth plate(large)	1
2	S150220002	Screw	5
3	182100020	Slide cover	1
4	182100021	Crank chamber cover	1
5	182100022	Crank chamber cover gasket	1
6	S150238001	screw	7
7	110100003	Seal plug	5
8	110100026	Seal plug	1
9	110100017	Rear cover gasket	1
10	110100016	Rear cover	1
11	B62400812	Screw	7
12	110200025	Needle bar guard	1
13	182100028	Supplementary slide cover	1
14	182100030	Stitch plate support	1
15	B62400812	Screw	2
16	182100031	Feed regulating pushbutton	1
17	182100032	Feed regulating pushbutton spring	1
18	S4B1202008	Retaining ring	1
19	182130000	Oil defender	1
20	S150237002	Screw	3
21	182100035	Screw	2
22	S120501003	Nut	1
23	110150002	Front cover hinge	1
24	S150237003	Screw	2
25	182150002	Front cover(lower)	1
26	110150003	Screw	1
27	S150643001	Conical spring washer	2
28	S150224001	Screw	1
29	110150004	Screw	1
30	182150005	Suppiementary front cover(see the below)	1
31	S8A3103003	Washer	4
32	S8A3103006	Washer	2
33	S150217003	Screw	2
34	182150006	Front cover(upper)	1
35	S120205001	Screw	3
36	B62401012	Screw	5
37	182140005	Cover latch spring	1
38	182150007	Supplementary tension disc cover	1
39	S150237008	Screw	2
40	110500021	Eyelet cover(see the below)	1
41	B62400812	Screw	2
42	182100037	Seal plug	1
43	182100038	Seal plug	1
44	B12060632	Screw	1

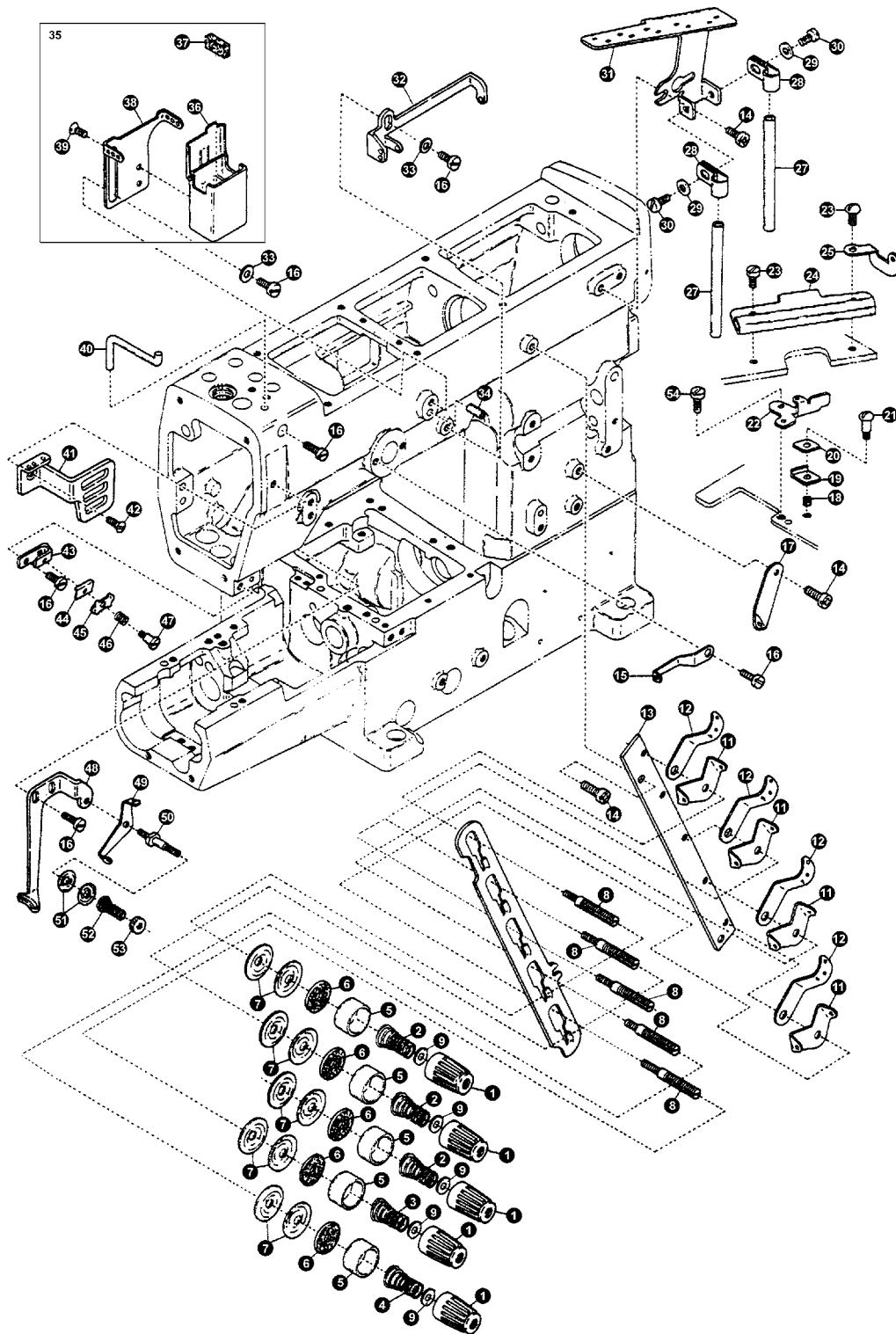

3. MISCELLANEOUS THREAD EYELETS

No.	Ret. No.	Description	Qt
1	028283005	Thread tension spring cap	5
2	028283001	Needle thread tension spring	3
3	028283002	Top cover thread tension spring	1
4	028283007	Looper thread tension spring	1
5	028280002	Thread tension spring retainer	5
6	028283007	Felt	5
7	022160005	Tension disc	10
8	1102h0003	Tension post	5
9	028283004	Tension post ferrule	5
10	1102h0002	Tension disc separator	1
11	116200016	Tension disc eyelet	5
12	116200015	Thread lead – in guide	5
13	1102h0001	Tension post support	1
14	B62400812	Screw	5
15	110200019	Top cover thread eyelet (left)	1
16	B62400812	Screw	7
17	110500020	Looper thread eyelet (long)	1
18	182200003	Supplementary tension spring	1
19	182200004	Supplementary tension disc (lower)	1
20	182200005	Supplementary tension disc (upper)	1
21	182200006	Screw	1
22	182200007	Tension disc guide	1
23	S150237008	Screw	2
24	182200008	Looper thread guard	1
25	182200009	Looper thread eyelet (center)	1
27	116250003	Thread eyelet pipe (short)	2
28	116250002	Thread eyelet pipe stay	2
29	SFB0601008	Washer	2
30	S150237002	Screw	2
31	116250001	Thread guide plate	1
32	110200027	Top cover thread eyelet (right)	1
33	S8A3103003	Washer	2
34	110100027	Guide pin	1
35	1102K0000	SP Device, complete set	1
36	1102K0001	SP Container	1
37	1102K0004	Felt	1
38	1102K0002	Needle thread eyelet	1
39	S150241001	Screw	2
40	110200026	Needle thread guide	1
41	110200009	Needle thread take – up guard	1
42	S150237002	Screw	1
43	110260004	Needle thread retainer support	1
44	110260003	Thread retaiher dise suppot	1

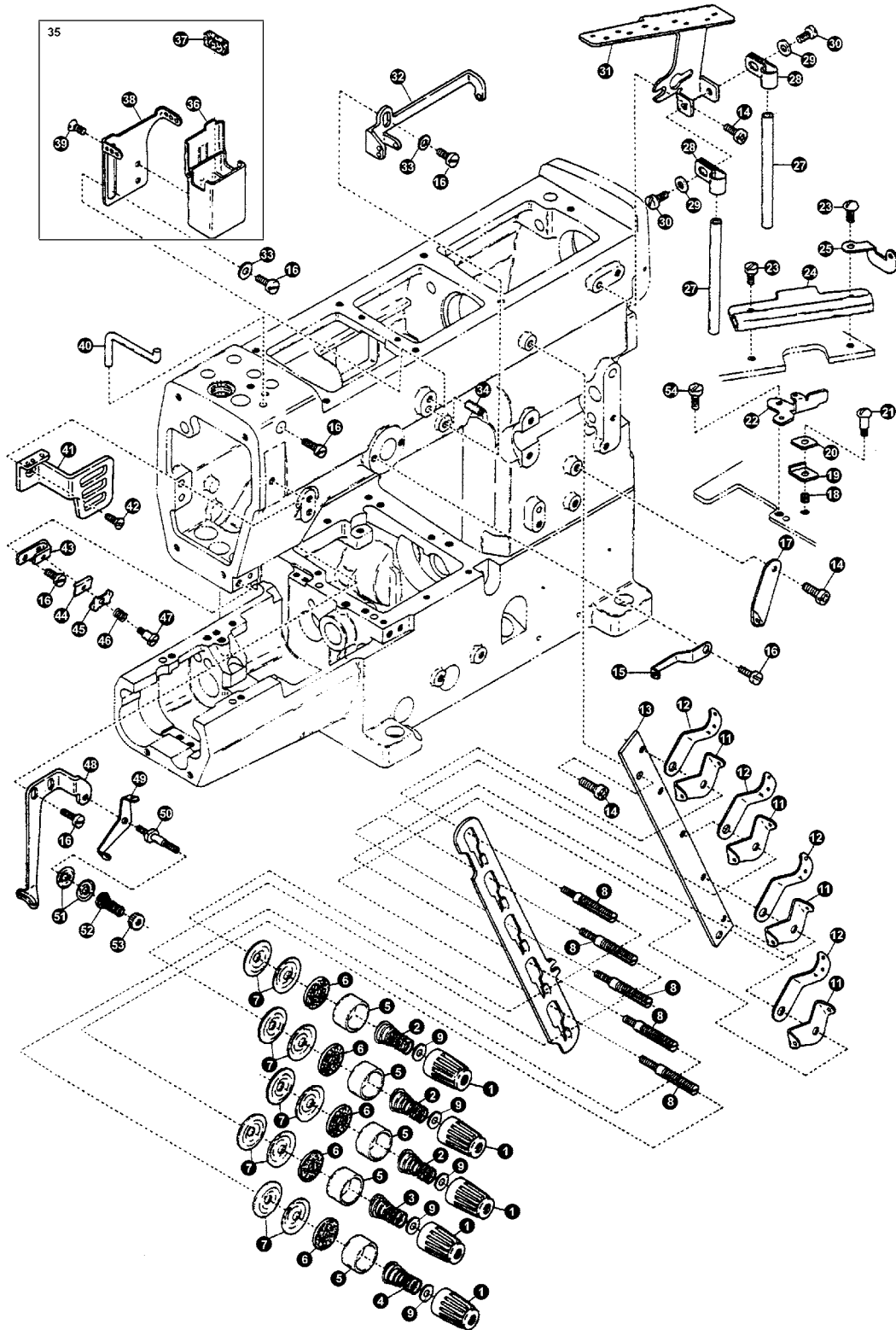

3. MISCELLANEOUS THREAD EYELETS

No.	Ret. No.	Description	Qt
45	110260001	Needle thread retainer dice	1
46	081130003	Needle thread retainer spring	1
47	110260002	Screw	1
48	182230001	Top cover thread guide	1
49	110200002	Supplementary thread guide	1
50	116200018	Tension post	1
51	008200068	Supplementary tension disc	2
52	008200067	Supplementary tension spring	1
53	008200088	Nut	1
54	S150237008	Screw	1

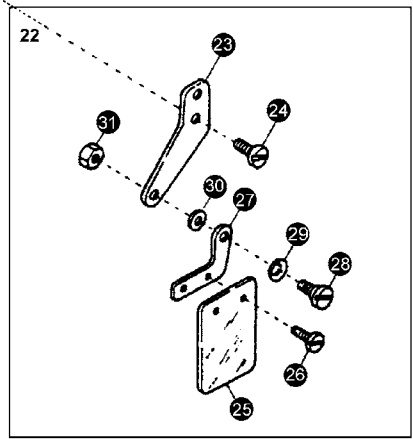
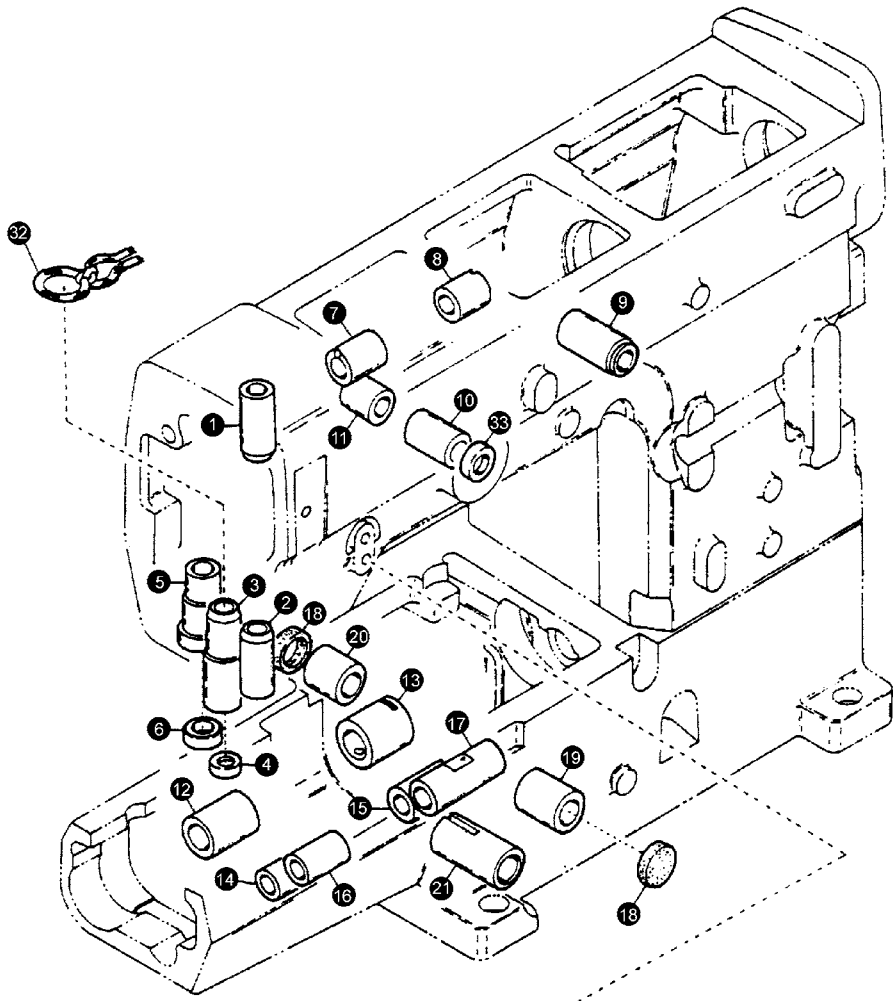

4. MISCELLANEOUS BUSHINGS

No.	Ret. No.	Description	Qt
1	110200002	Needle bar bushing(upper)	1
2	182300002	Needle bar bushing(lower)	1
3	182300003	Presser bar bushing	1
4	110600005	oil seal	1
5	110200018	Spreder driving bar bushing	1
6	008600015	Oil seal	1
7	110200016	Spreder driving shaft bushing(left)	1
8	110200017	Spreder driving shaft bushing(right)	1
9	110600009	Foot lifter lever bushing	1
10	110200008	Needle thread take – up bushing(fornt)	1
11	110200007	Needle thread take – up bushing(read)	1
12	182300013	lower shaft bushing(left)	1
13	182300014	lower shaft bushing(right)	1
14	182300015	Differential feed bar shaft bushing (left)	1
15	182300016	Differential feed bar shaft bushing (right)	1
16	182300017	Feedl bar lift shaft bushing (lift)	1
17	182300018	Feedl bar lift shaft bushing (right)	1
19	182300019	Looper driving shaft bushing(front)	1
20	182300020	Looper driving shaft bushing(rear)	1
21	182300021	Adjusting screw bushing	1
22	110140000	Eye guard, complete set	1
23	110140002	Eye guard support	1
24	110100019	Screw	1
25	116120001	Eye guard	1
26	S120203013	Screw	2
27	110140001	Eye guard holder	1
28	110100019	Screw	1
29	142100014	Conical spring washer	1
30	SFB0601001	Washer	1
31	S120501003	Nut	1
32	182300022	Oil wick	1
33	110280000	oil seal	1

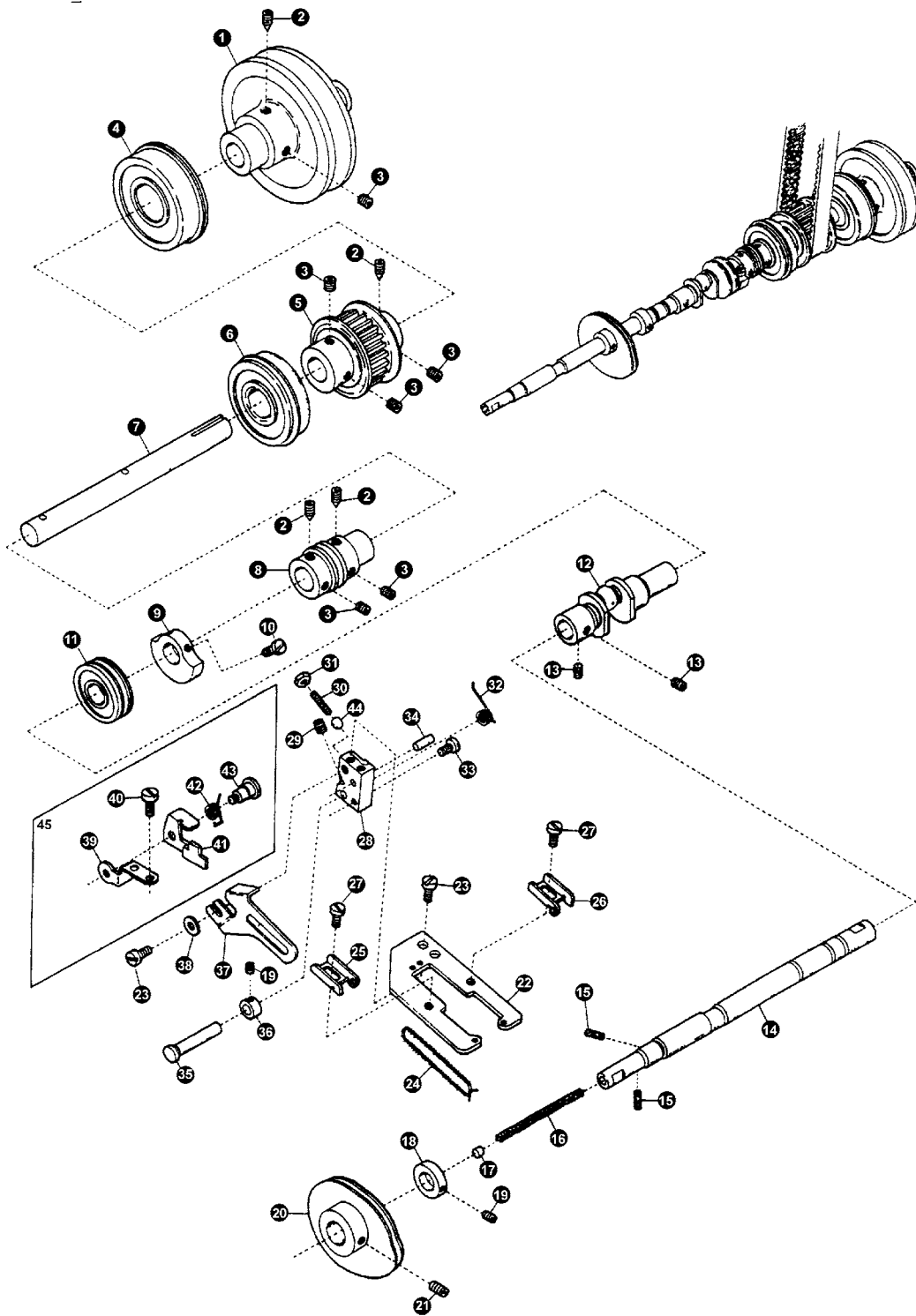

5. MAIN SHAFT DRIVING MECHANISM

No.	Ret. No.	Description	Qt
1	182400001	Pulley	1
2	S150224003	Screw	4
3	B12060632	Screw	6
4	S150866007	Ball bearing(right)	1
5	110520000	Main shaft sprocket(lower)	1
6	S150866006	Ball bearing (middle)	1
7	182400003	Lower shaft(right)	1
8	182400004	Oil pump driving worm	1
9	110200022	Counterweight (small)	1
10	B62400812	Screw	2
11	S150866013	Ball bearing(left)	1
12	182400006	Lower crankshaft	1
13	S150224007	Screw	2
14	182440001	Lower shaft(left)	1
15	182400010	Oil wick	2
16	182400011	Oil wick	1
17	182440002	Seal plug	1
18	182400013	Collar	1
19	S150224001	Screw	1
20	182410000	Looper thread take – up	1
21	B12500532	Screw	2
22	182420001	Supporting plate	1
23	B60300612	Screw	3
24	182420002	Laced wire	1
25	182420003	Thead take – up eyelet(left)	1
26	182420003	Thead take – up eyelet(right)	1
27	S150217001	Screw	2
28	182420005	Supporting plate basement	1
29	B12400432	Screw	1
30	S150226001	Stop screw	1
31	S120501011	Lock nut	1
32	182400015	Supporting plate return spring	1
33	S150217002	Screw	1
34	S150435002	Pin	1
35	182400017	Basement shaft	1
36	182400016	Collar	1
37	182420008	Cast – off plate	1
38	S8A3103002	Washer	1
39	182430001	Stop baracket	1
40	S150237002	Screw	2
41	182430002	Supporing plate stop	1
42	182430003	Stop spring	1
43	182430004	Screw	1
44	182400014	Basement cushion	1
45	182430000	Supporting plate stop, C. set	1

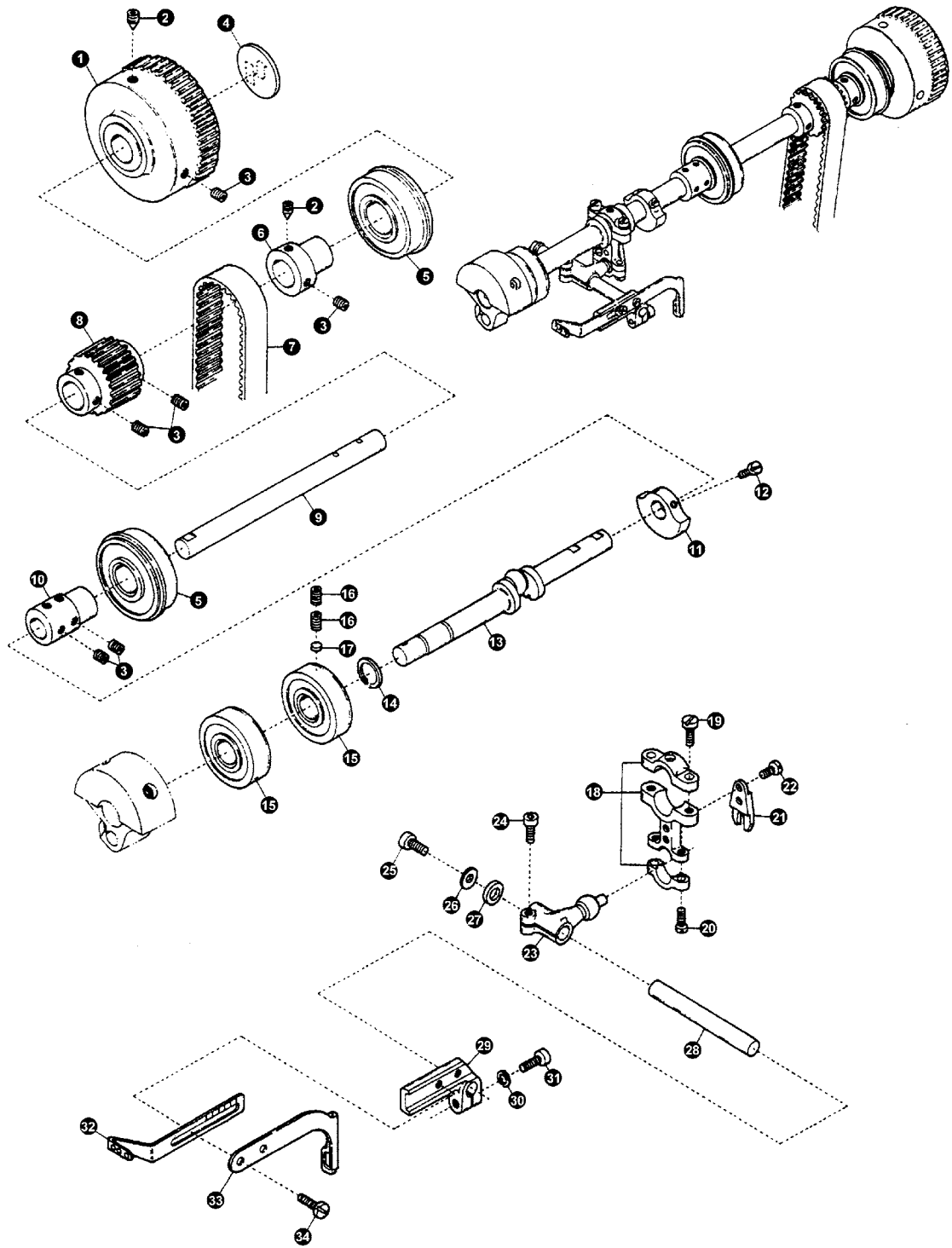

6. MISCELLANEOUS COVERS(1)

No.	Ret. No.	Description	Qt
1	182520001	Handwheel	1
2	W120216003	Screw	2
3	B12060632	Screw	10
4	110100025	Handwheel mark	1
5	S150866006	Ball bearing	2
6	1102f0001	Handwheel adapter	1
7	110200023	Timing belt	1
8	1102g0001	Upper shaft sprocket(upper)	1
9	110200021	Upper shaft(right)	1
10	1102d0001	Upper shaft joint	1
11	110200022	Counterweight(small)	1
12	B62400812	Screw	2
13	110200020	Upper crankshaft	1
14	S4A0500010	Retaining ring	1
15	052200036	Ball bearing	2
16	B12060632	Screw	2
17	110200024	Rubber seat	1
18	110270000	Connecting rod	1
19	S150220009	Screw	2
20	SFB0201005	Screw	2
21	110270002	Guide fork	1
22	B60300612	Screw	2
23	110270003	Driving lever	1
24	B18061632	Screw	1
25	S150217003	Screw	1
26	110200005	Washer	1
27	110200006	Spacer	1
28	110200004	Driving shaft	1
29	110290001	Bracket	1
30	S8A3103006	Spring washer	1
31	S150220004	Screw	1
32	110290002	Needle thread take – up	1
33	110290003	Top cover thread take – up	1
34	B62400812	Screw	2

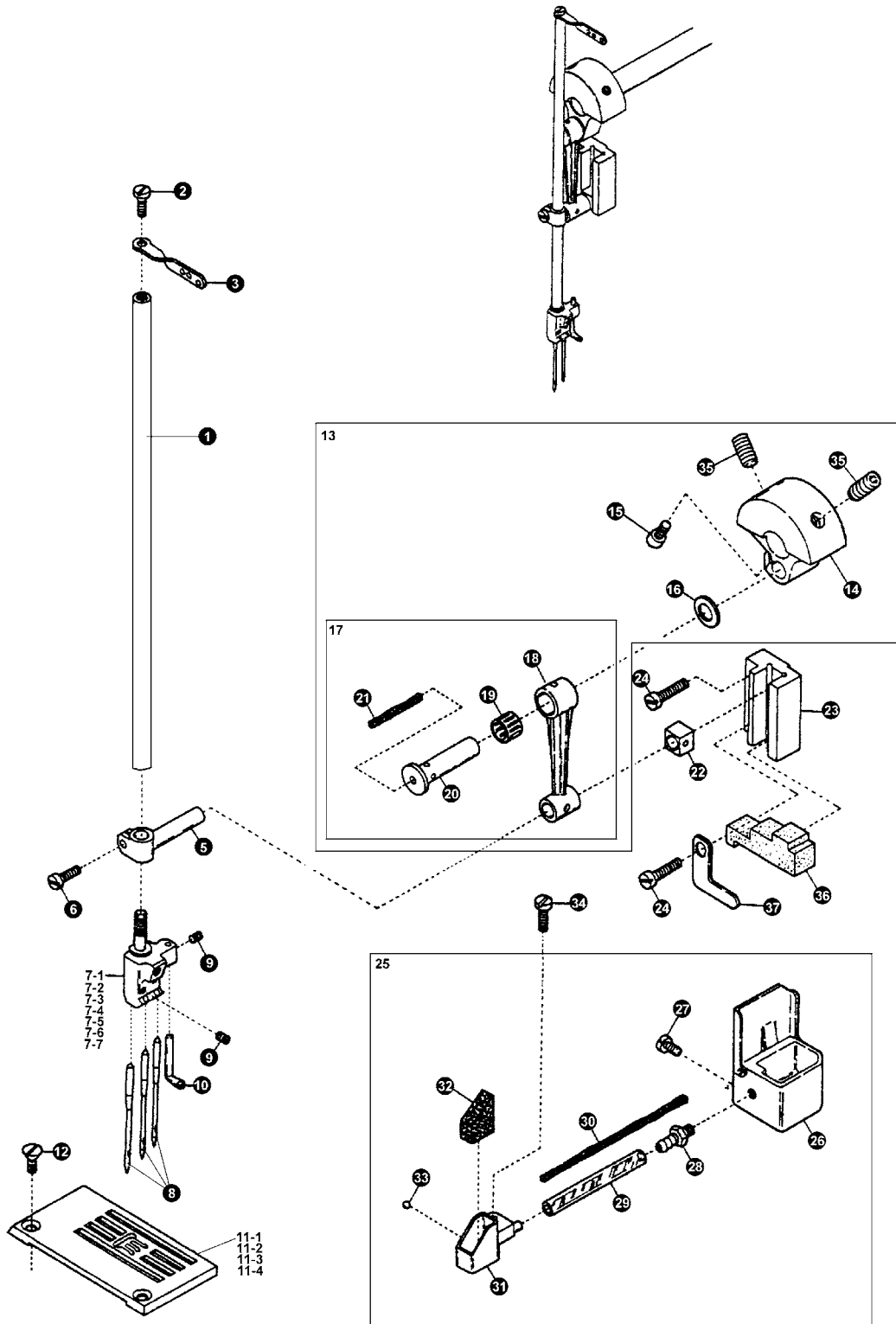

7. NEEDLE BAR MECHANISM

No	Ret. No.	Description	Qt
1	182600019	Needle bar	1
2	116240003	Screw	1
3	116240002	Needle bar thread eyelet	1
5	110220005	Needle bar bracket	1
6	B62401012	Screw	1
7 -1	182610001	Needle clamp	1
7 -2	182610002	Needle clamp	1
7 -3	182610003	Needle clamp	1
7 -4	182610004	Needle clamp	1
7 -5	182610005	Needle clamp	1
7 -6	182610006	Needle clamp	1
7 -7	182610007	Needle clamp	1
8	S150901001	Needle	2(3)
9	182610010	Screw	3(4)
10	182610009	Top cover thread eyelet	1
11 -1	182600008	Stitch plate	1
11 -2	182600009	Stitch plate	1
11 -3	182600010	Stitch plate	1
11 -4	182600011	Stitch plate	1
11 -5	182600012	Stitch plate	1
11 -6	182600013	Stitch plate	1
11 -7	182600014	Stitch plate	1
12	110400023	Screw	2
13	110220000	Cpunterweight, complete set	1
14	110220001	Cpunterweight	1
15	S150220007	Screw	1
16	110220003	Connecting rod ring	1
17	182620000	Connecting rod , complete set	1
18	110220004	Connecting rod	1
19	S150866005	Roller bearing	1
20	110220002	Connecting rod pin	1
21	182620001	Oil wick	1
22	110220006	Slide block	1
23	110230001	Needle bar guide	1
24	S150237003	Screw	2
25	182630000	HR device, complete set	1
26	182631000	HR container	1
27	B62400812	Screw	2
28	182630001	Pipe joint	1
29	182630002	Oil tube	1
30	182630003	Felt	1
31	182630004	HR cup	1
32	182630005	HR felt	1
33	0527300101	Seal plug	1

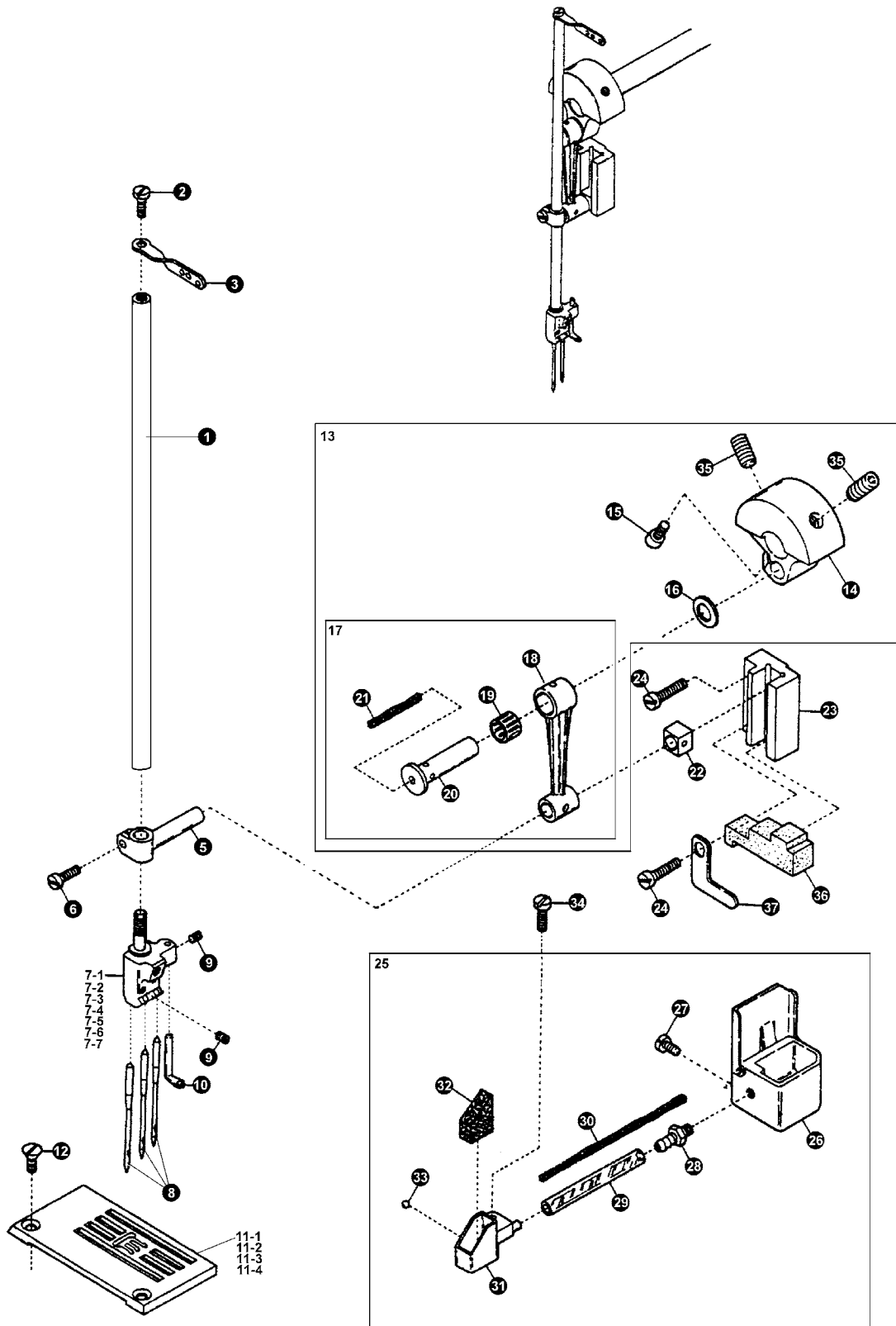

7. NEEDLE BAR MECHANISM

No.	Ret. No.	Description	Qt
34	B62400812	Screw	1
35	S150224002	Screw	2
36	110200032	Sponge	1
37	110200033	Fixing plate	1

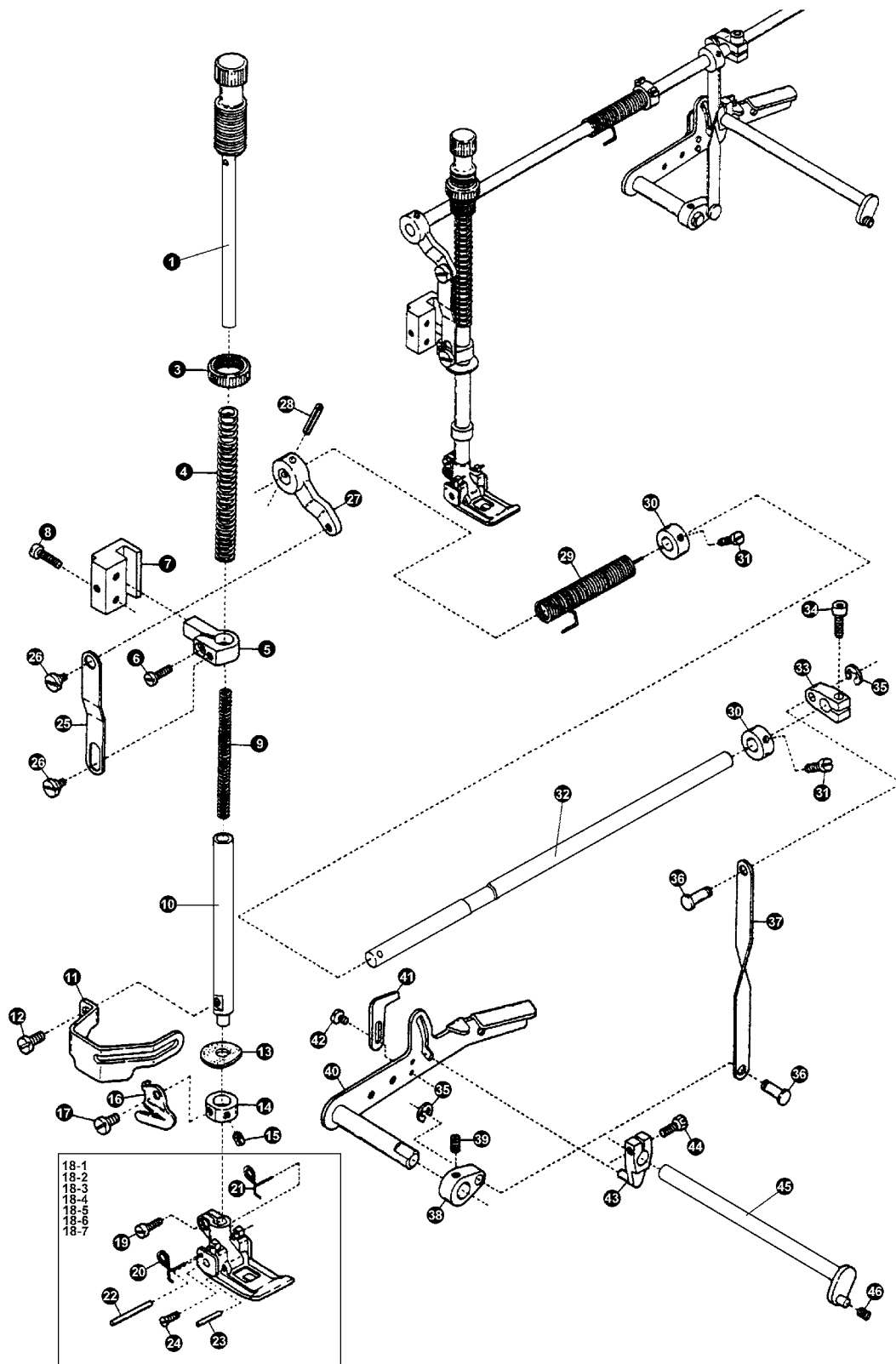

8. PRESSER FOOT MECHANISM

No.	Ret. No.	Description	Qt
1	110610001	Presser spring regulateor	1
3	110610002	Lock nut	1
4	110600001	Presser bar spring(outer)	1
5	110620000	Presser bar connecting bracket	1
6	S150237004	Screw	1
7	110600004	Presser bar guide	1
8	S150237003	Screw	2
10	182700005	Presser bar	1
11	110600012	Finger guard	1
12	S150237002	Screw	1
13	182700003	Oil protector ring	1
14	110600006	Collar	1
15	B12400432	Screw	2
16	110600013	Thread chain cutting knift	1
17	S150239001	Screw	1
18 - 1	182710000	Presser foot, complete set	1
18 - 2	182710000	Presser foot, complete set	1
18 - 3	182710000	Presser foot, complete set	1
18 - 4	182710000	Presser foot, complete set	1
18 - 5	182710000	Presser foot, complete set	1
18 - 6	182710000	Presser foot, complete set	1
18 - 7	182710000	Presser foot, complete set	1
19	B62400812	Screw	1
20	182710012	Presser foot spring(lete)	1
21	182710013	Presser foot spring(right)	1
22	S150446005	Locking pin	
23	182710015	Presser foot hinge pin	1
24	S150218001	Screw	2
25	110630004	Lifter link	1
26	110630003	Screw	2
27	110630002	Lifter link lever	1
28	S150446009	Fastener pin	1
29	110600008	Lifter spring	1
30	110640001	Collar	2
31	S150237002	Screw	4
32	110630001	Lifter shaft	1
33	110650002	Lntermendiate lever	1
34	S150220003	Screw	1
35	S4A0105006	Retaining ring	2
36	110650003	Connecting pin	2
37	110650001	Connecting plate	1
38	110650004	Lifter lever(small)	1
39	022540004	Screw	1
40	110681000	Lifter lever	1

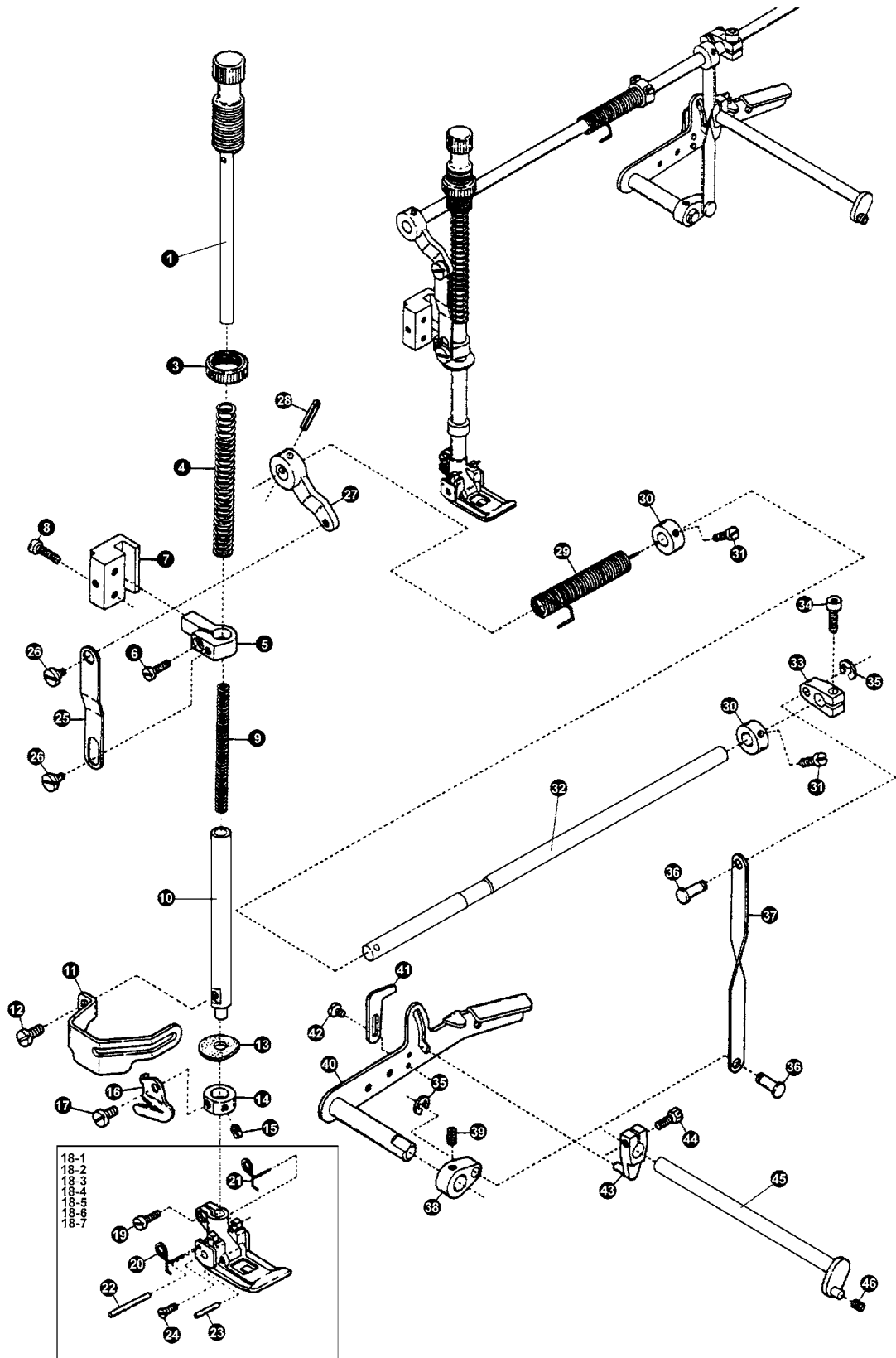

8. PRESSER FOOT MECHANISM

No.	Ret. No.	Description	Qt
41	110680001	Lifter lever stop	1
42	S150237002	Screw	2
43	110671000	Tension release lever	1
44	S120104019	Screw	1
45	110660000	Tension release shaft	1
46	110200034	Swing –proof spring	1

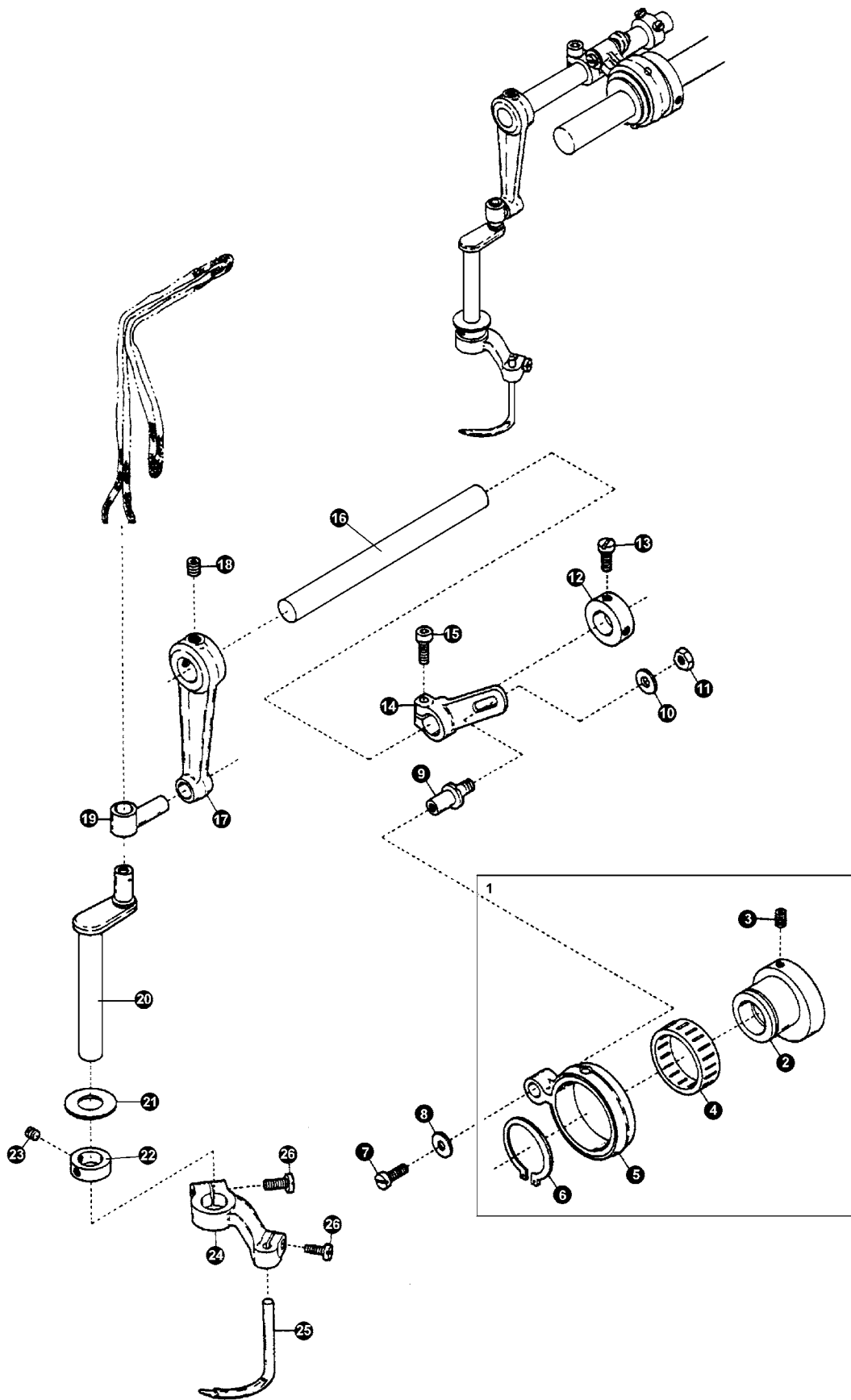

9. SPREADER MECHANISM

No.	Ret. No.	Description	Qt
1	1102a0000	Connecting rod, complete set	1
2	1102a0001	Eccentric	1
3	B12500532	Screw	2
4	S150866002	Roller bearing	1
5	1102a0002	Connecting rod	1
6	S150649001	Retaining ring	1
7	B62400812	Screw	1
8	1102a0004	Washer	1
9	1102a0003	Adjusting lever pin	1
10	S150633001	Washer	1
11	S120501011	Nut	1
12	028200026	Collar	1
13	028100068	Screw	2
14	1102a0005	Adjusting lever	1
15	B18061632	Screw	1
16	110200010	Driving shaft	1
17	1102b0001	Rocking arm	1
18	B12060632	Screw	2
19	1102b0002	Rocking pin	1
20	110200011	Spreader bar	1
21	110200012	Bushing Ring	1
22	110400006	Collar	1
23	B12400432	Screw	2
24	110200013	Spreader holder	1
25	110200014	Spreader	1
26	B62401612	Screw	2

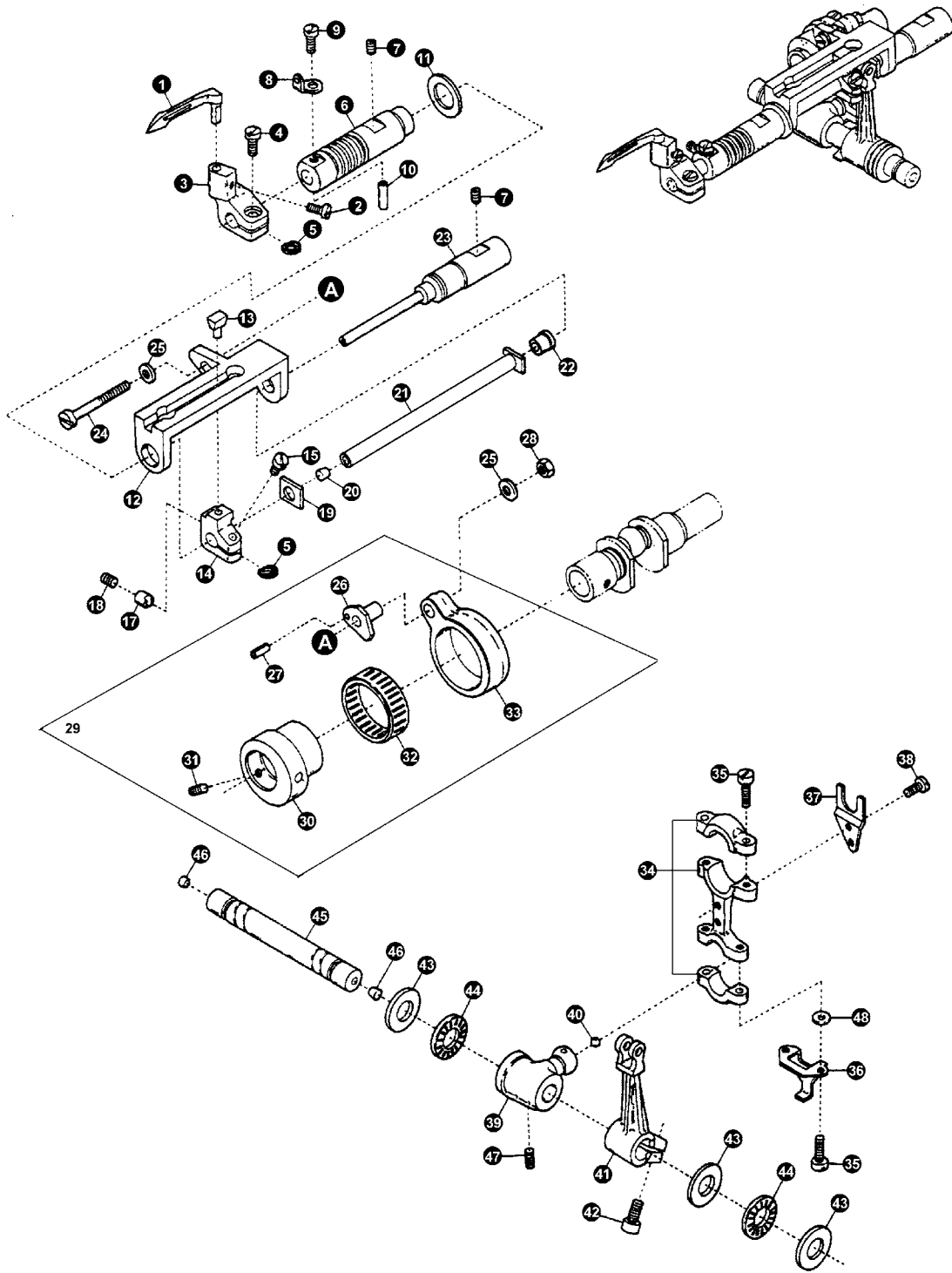

10. LOOPER DRIVING MECHANISM

No.	Ret. No.	Description	Qt
1	182900001	Looper	1
2	B60300612	Screw	1
3	182900002	Looper holder	1
4	B62401012	Screw	1
5	182900003	Spacer(fiber)	2
6	182900004	Looper bar bushing	1
7	B12060632	Screw	2
8	182900005	Looper thread eyelet	1
9	S150239001	Screw	1
10	S150446004	Roll pin	1
11	182900007	Bushing spacer	1
12	182900008	Looper bar guide	1
13	182900009	Slider	1
14	182900010	Slider holder	1
15	S150220002	Screw	1
17	182900011	Slider Presser	1
18	B12400432	Screw	1
19	182900012	Thrust Washer	1
20	182910001	Seal plug(kurk)	1
21	182910002	Looper bar	1
22	182910003	Guide shaft bushing	1
23	182900013	Looper Bar guide shaft	1
24	S150237005	Screw	1
25	S8A3103006	Washer	2
26	182920001	Looper rocker adjusting pin	1
27	S150446003	Roll pin	1
28	S120503010	Nut	1
29	182930000	Looper rocker connecting rod, c.	1
30	182930001	Looper rocker Regulating eccentri	1
31	B12500532	Screw	1
32	S150866004	Roller bearing	1
33	182930002	Looper Rocker connecting rod	1
34	182940001	Looper connecting rod	1
35	B62401412	Screw	4
36	182940003	Oil splasher	1
37	182940002	Guide fork	1
38	B62400812	Screw	2
39	182941001	Looper Driving Lever	1
40	182941002	Seal plug	1
41	182900016	Looper rocker arm	1
42	S150220005	Screw	1
43	S150866008	Thrust washer	3
44	S150866008	Thrust Roller bearing	2
45	182950001	Looper shaft	1
46	182950002	Seal plug	2
47	B12060632	Screw	2
48	S8A3103008	Washer	2

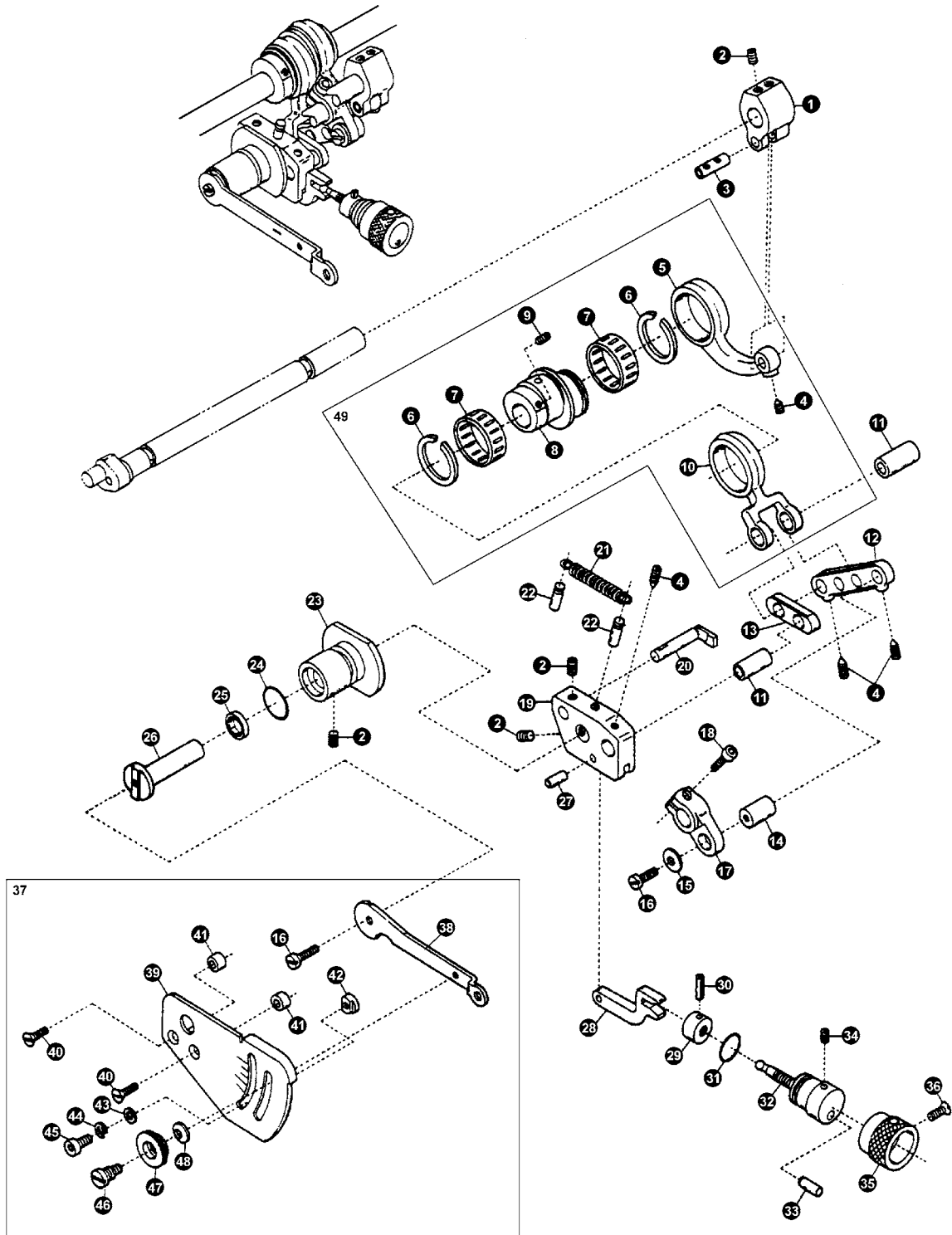

11. FEED CONTROL MECHANISM

No.	Ret. No.	Description	Qt
1	182A00001	Feed lift lever	1
2	B12060632	Screw	5
3	182A00002	Connecting rod pin	1
4	S23342001	Screw	4
5	182A10001	Feed lift connecting rod	1
6	S150649002	Retaining ring	2
7	S150866003	Roller bearing	2
8	182A10002	Differential feed eccentric	1
9	B12500532	Screw	2
10	182A10003	Differential feed connecting rod	1
11	182A00028	Connecting rod pin	2
12	182A00004	Lever link (long)	1
13	182A00005	Lever link (short)	1
14	182A00006	Lever link pin	1
15	182A00029	Washer	1
16	B62400812	Screw	2
17	182A00007	Differential feed shaft lever	1
18	S150220002	Screw	1
19	182A00008	Control bracket	1
20	182A00009	Connecting rod guide	1
21	182A00010	Control bracket spring	1
22	182A00011	Pin	2
23	182A00012	Control lever shaft bushing	1
24	S150656002	O – ring	1
25	110280000	Oil seal	1
26	182A00014	Contral lever shaft	1
27	182A00015	Contral link pin	1
28	182A00016	Contral link	1
29	182A20001	Contral nut	1
30	S150446006	Roll pin	1
31	S150656002	O – ring	1
32	182A00017	Adjusting screw	1
33	S150435001	Adjusting stop pin	1
34	B12400432	Screw	1
35	182A00021	Adjusting knob	1
36	S120205001	Screw	1
38	182A00022	Differential feed conral lever	1
39	182A00023	Differential feed graduations	1
40	B62401012	Screw	2
41	182A00024	Spacer	2
42	182A00025	Control lever stop	1
43	S8A3103006	Washer	1
44	S4B3000009	Spring washer	1
45	S150220001	Screw	1
46	182A00026	Screw	1
47	182A00027	Nut	1
48	S150643001	Conical spring washer	1
49	182A10000	Feed lift connecting rod, C. set	1

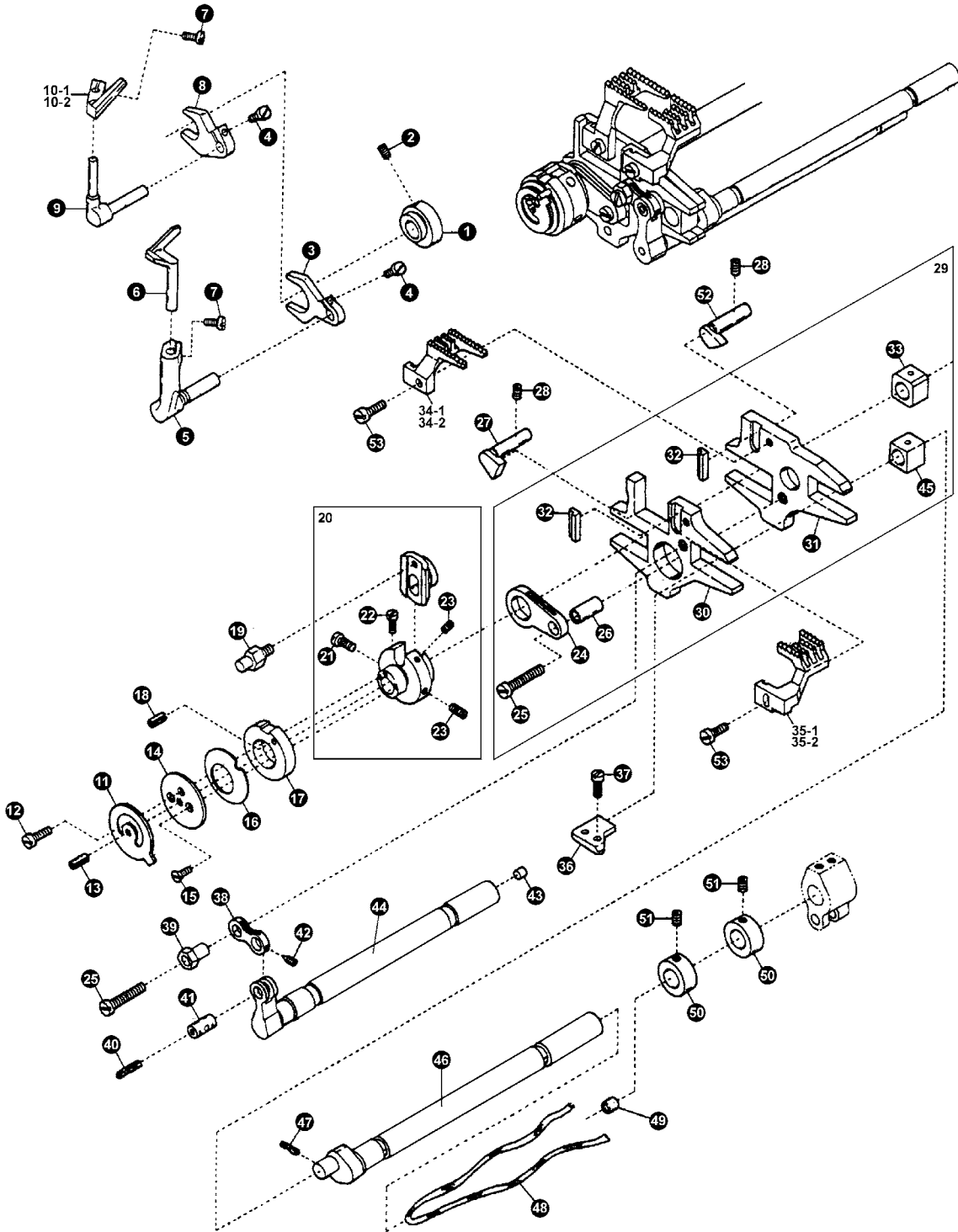

12. NEEDLE GUARD & FEED DRIVING MECHANISM

No.	Ret. No.	Description	Qt
1	182C00001	Needle guard(front) eccentric	1
2	B12500532	Screw	2
3	182C00002	Needle guard(front) lever	1
4	B62300812	Screw	2
5	182C00003	Needle guard(front) holder	1
6	182C00004	Needle guard(front)	1
7	B60300612	Screw	2
8	182C00005	Needleguard(rear)lever	1
9	182C00006	Needleguard(rear)holder	1
10	182C00007	Needle guard(rear)	1
11	182C10007	Feed regulating stop	1
12	043300022	Screw	1
13	S150446007	Roll pin	1
14	182C10006	Conical speing presser	1
15	S150218002	Screw	2
16	182C10005	Conical spring	1
17	182C10004	Eccentric cam	1
18	S150435007	Stop pin	1
19	182C10003	Eccentric pin	1
20	182C10000	Main feed eccentric, complete set	1
21	B60300612	Screw	1
22	S150217004	Screw	1
23	B12400432	Screw	2
24	182C00014	Main feed bar driving connection	1
25	S150237001	Screw	2
26	182C00015	Deiving connection bushing	1
27	182C00016	Feed bar guide	1
28	B12060632	Screw	2
30	182C00017	Differential feed bar	1
31	182C00018	Main feed bar	1
32	182C00019	Feed dog key	2
33	182C00020	Feed lift block(rear)	1
34	182C00021	Main feed dog	1
35	182C00022	Differential feed dog	1
36	182C00023	Feed bar guide(lover)	1
37	B62401012	Screw	2
38	182C00024	Differential feed bar driving cor	1
39	182C00025	Oscillation adjusting eccentric	1
40	182C00027	Oil wick	1
41	182C00026	Driving connection pin	1
42	S150224001	Screw	1
43	182C20002	Set plug	1
44	182C20001	Differential feed shaft	1
45	182C00028	Feed lift block(front)	1

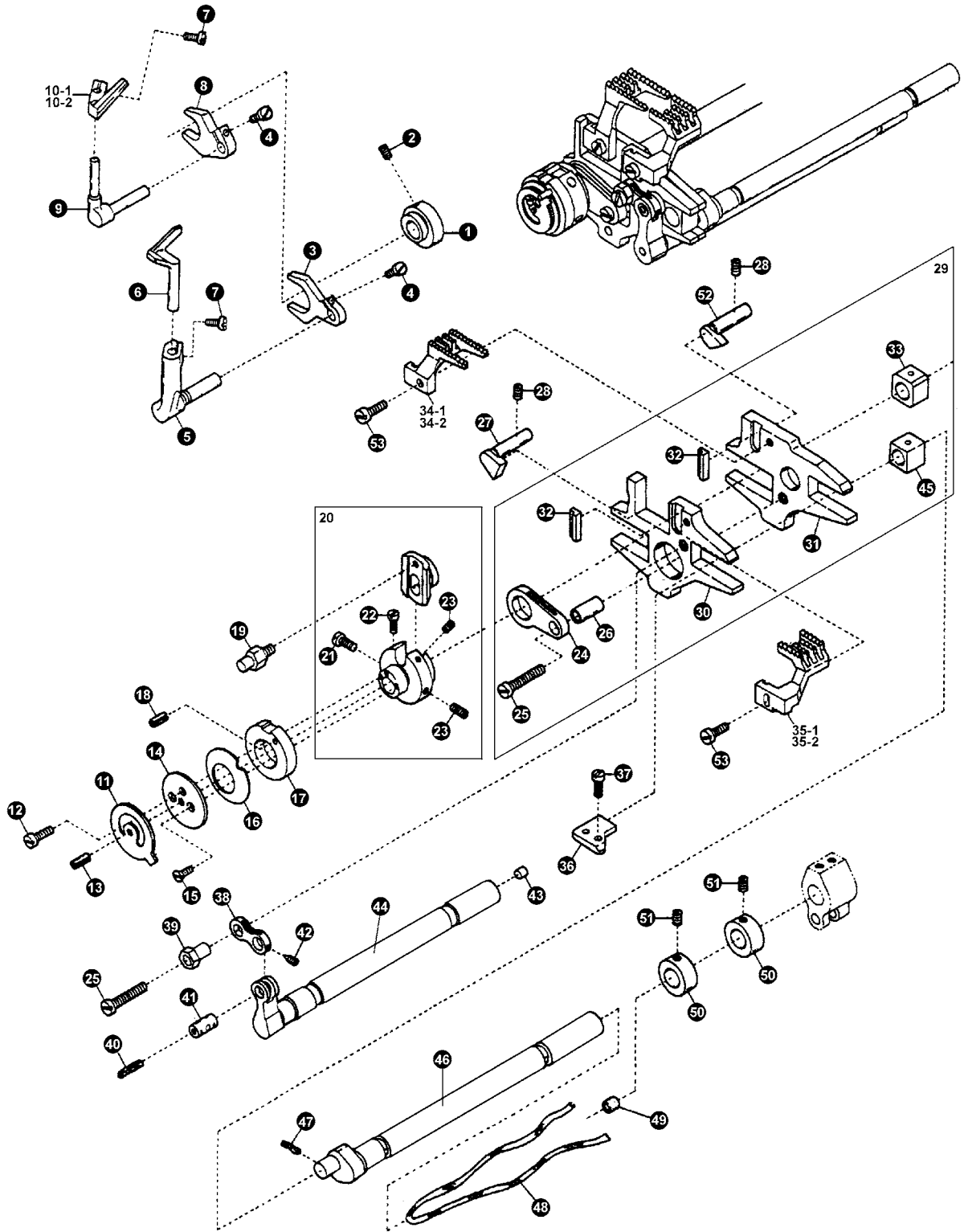

12. NEEDLE GUARD & FEED DRIVING MECHANISM

No.	Ret. No.	Description	Qt
46	182C30001	Feed lift shaft	1
47	182C00029	Oil wick	1
48	182C00030	Oil wick	1
49	182C30002	Seal plug	1
50	182C00031	Collar	2
51	B12060632	Screw	2
52	182C00032	Feed bar guide(upper/right)	1
53	B12060632	Screw	2

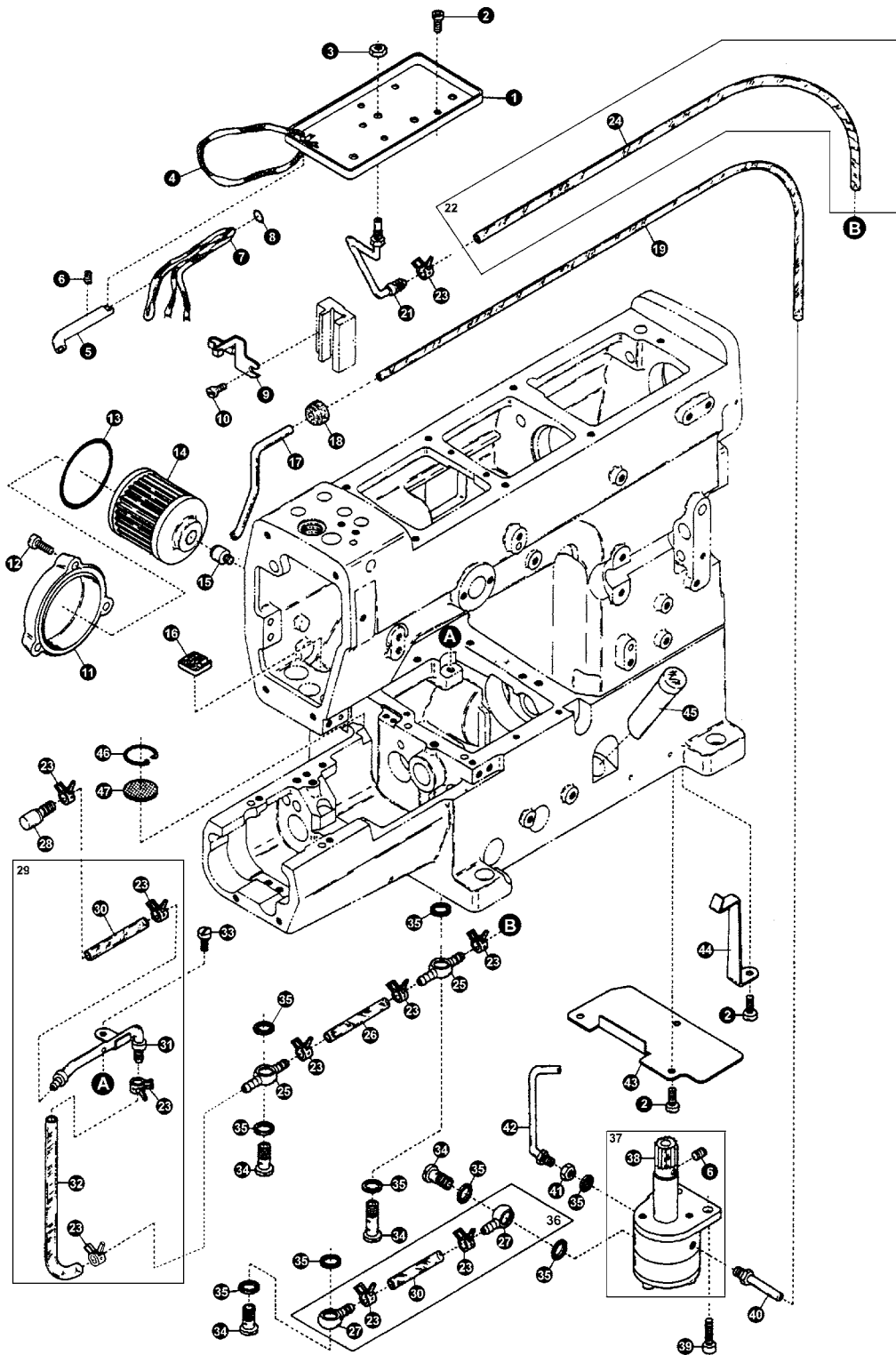

13. LUBRICATING MECHANISM

No.	Ret. No.	Description	Qt
1	110300003	Oil receiver	1
2	S150237002	Screw	6
3	S120501011	Nut	1
4	110200029	Oil wick	1
5	110200028	Needle bar connecting rod oil pi	1
6	B12400432	Screw	3
7	110200030	Oil wick	1
8	S150656001	O –ring	1
9	110230002	Oil wick holder	1
10	B60300612	Screw	1
11	028700023	Oil filter cap	1
12	B62401012	Screw	3
13	S8A3107004	O –ring	1
14	028770001	Oil filter	1
15	028700022	Oil filter connector	1
16	110300007	Felt	1
17	110300010	Suction pipe	1
18	110300011	Suction pipe bushing	1
19	110300008	Oil tube	1
21	110330000	Oil sight top nozzle	1
23	028700011	Oil tube clamp	12
24	182D00011	Oil tube	1
25	110340001	Oil tube joion. two way	2
26	182D00014	Oil tube	1
27	028700010	Oil tube joion. one way	2
28	182D00027	Lower shaft oiling outlet	1
30	182D00020	Oil tube	2
31	182D20000	Lower shaft oiling shower	1
32	182D00018	Oil tube	1
33	B62400812	Screw	1
34	028700012	Fitting stud(short)	4
35		Seal	8
37	110360000	Oil pump, complete set	1
38			1
39	S150220005	Screw	2
40	110362000	Suction pipe	1
41	S120501011	Nut	1
42	110361000	Oil nozzle for worm gear	1
43	182D00026	Dust proof plate	1
44	182D00025	Oil tube stay	1
45	110300002	Oil sight gauge	1
46	110300006	Oil filter screen clamp	1
47	110300005	Oil filter screen	1

GK32700

**HIGH-SPEED CYLINDER-BED
INTERLOCK SEWING MACHINE**



XI'AN TYPICAL INDUSTRIES CO., LTD.

No. 335, South Taibai Road
Xi'an 710068, P.R.China
Tel.: +86-29-88279093 // 88279150 // 88279151
Fax: +86-29-88249715 // 88245215

E-mail: tic@chinatypical.com
www.chinatypical.com

XI'AN TYPICAL EUROPE GmbH

Hertelsbrunnenring 9
D-67657 Kaiserslautern
Tel.: +49 (0)631 316019-0
Fax: +49 (0)631 316019-11

E-mail: sales@typical-europe.com
www.typical-europe.com