

**EN Technical Data**

- Stitch type 301 Lockstitch
- Max. sewing speed 2,000 spm  
**(TW1-1245 / -V / -D2-T3)**
- Max. stitch length 8.0 mm
- Max. top feed stroke 7.0 mm
- Max. fabric clearance 14 mm
- Needle system 134-35
- Needle size Nm 90-150
- Balance wheel 80 mm eff. Dia.
- Recommended motor power minimum 0.55 kW

**Clearance under the arm**

- **TW1-1245** 257×110 mm
- **TW1-1245-HL14** 365×130 mm
- **TW1-1245-HL30** 750×130 mm

**Carton dimensions & gross weights for sewing head**

- **TW1-1245** 63×28×60 cm 44 kg
- **TW1-1245-HL14** 75×30×62 cm 53 kg
- **TW1-1245-HL30** 123×41×65 cm 120 kg

-V = binding attachment synchronized with feed movement  
Specifications can differ depending on model.

**DE Technische Daten**

- Stichtyp 301 Doppelsteppstich
- Max. Nähgeschwindigkeit 2.000 Stiche / Minute  
**(TW1-1245 / -V / -D2-T3)**
- Max. Stichtlänge 8,0 mm
- Max. Obertransporthub 7,0 mm
- Max. Durchgangsraum unter den Nähfüßen 14 mm
- Nadelsystem 134-35
- Nadelstärke Nm 90-150
- Handraddurchmesser effektiv 80 mm
- Empfohlene Motorleistung mind. 0,55 kW

**Durchgangsraum im Nähmaschinenarm**

- **TW1-1245** 257×110 mm
- **TW1-1245-HL14** 365×130 mm
- **TW1-1245-HL30** 750×130 mm

**Kartonmaße & Brutto-Gewichte für Nähkopf**

- **TW1-1245** 63×28×60 cm 44 kg
- **TW1-1245-HL14** 75×30×62 cm 53 kg
- **TW1-1245-HL30** 123×41×65 cm 120 kg

-V = mitgehender Bänderfasser  
Angaben können je nach Ausführung abweichen.



TW1-1245-		•	2,000	•	8.0	134-35 90-150	36	•	10/14	20/3	-	-	-	M
	V	•	2,000	•							-	-	-	M
	D2-T3	•	2,000	•							•	•	•	M
	HL14	•	1,800	•							-	-	-	M
	HL14-D2-T3	•	1,800	•							•	•	•	M
HL30-D2-T3	•	1,500	•	•	•	•	M							

# TW1-1245

**COMPOUND FEED LOCKSTITCH SEWING MACHINE  
3-FACH-TRANSPORT-, DOPPELSTIEPPSTICH-NÄHMASCHINE**



**XI'AN TYPICAL EUROPE GmbH**  
Hertelsbrunnenring 9  
D-67657 Kaiserslautern  
Tel.: +49 (0)631 316019-0  
Fax: +49 (0)631 316019-11

E-mail: [sales@typical-europe.com](mailto:sales@typical-europe.com)  
[www.typical-europe.com](http://www.typical-europe.com)



TW1-1245 – en/de – 05-2013

# TYPICAL

## EN Features & Benefits

- Compound feed
- Large hook
- 2.5–7 mm top feed stroke allows easy sewing – even at cross-seams
- 14 mm clearance under the lifted sewing feet for easy loading and unloading
- Max. 8 mm stitch length adjustable – forwards and backwards
- Hook protection against thread jamming realized by overload coupling
- Automatic hook lubrication
- Integrated bobbin winder

### Subclass D2:

Inclusive thread trimmer, automatic back tack & pneumatic presser foot lift

### Application:

Upholstery industry, automotive industry, leather industry, technical textiles, etc.  
(TW1-1245-D2-T3)

## DE Merkmale & Vorteile

- 3-Fach-Transport
- Großer Greifer
- 2,5–7 mm Obertransporthub für sicheres Transportieren – auch über Quernähte
- 14 mm Durchgangsraum unter den Nähfüßen für einfaches Einlegen und Entnehmen des Nähguts
- Max. 8 mm Stichlänge – Vorwärts und Rückwärts
- Greiferschutz gegen Fadeneinschlag durch Rutschkupplung
- Automatische Greiferschmierung
- Integrierter Unterfadenspuler (TW1-1245-D2-T3)

### Unterklasse D2:

Beinhaltet Fadenschneiden, automatische Verriegelungseinrichtung & pneumatisches Nähfußlüften

### Anwendungen:

Polsterindustrie, Automobilindustrie, Lederindustrie, technische Textilien, usw.

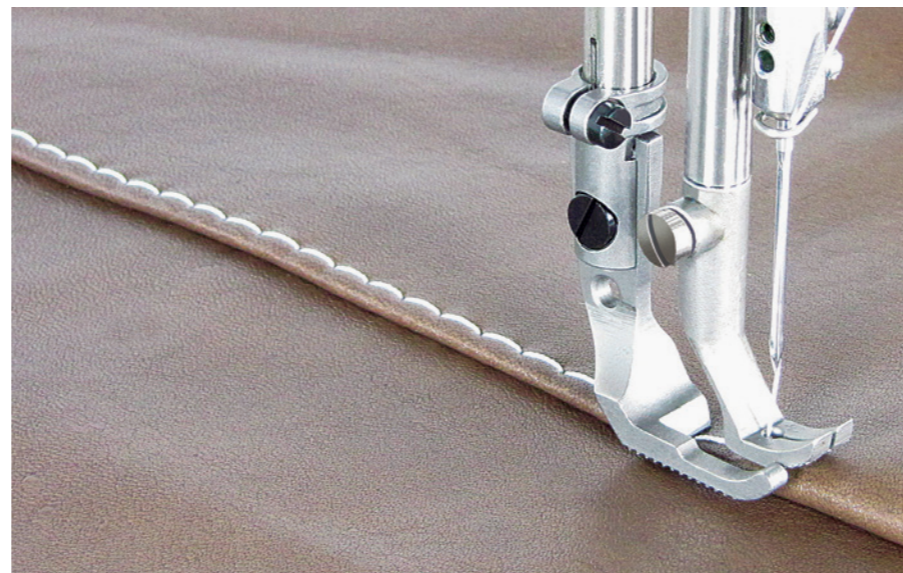
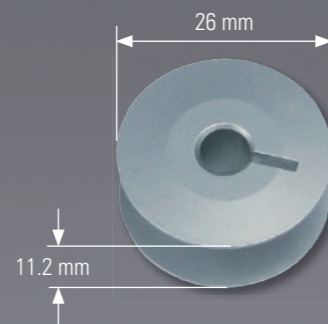

TW1-1245

-V- = binding attachment synchronized with feed movement / mitgehender Bändeinfasser

### TW1-1245

Clearance under the arm: 257×110 mm  
Durchgangsraum im Nähmaschinenarm:  
257×110 mm



### TW1-1245HL14

Clearance under the arm: 365×130 mm  
Durchgangsraum im Nähmaschinenarm: 365×130 mm



### TW1-1245HL30

Clearance under the arm: 750×130 mm  
Durchgangsraum im Nähmaschinenarm: 750×130 mm

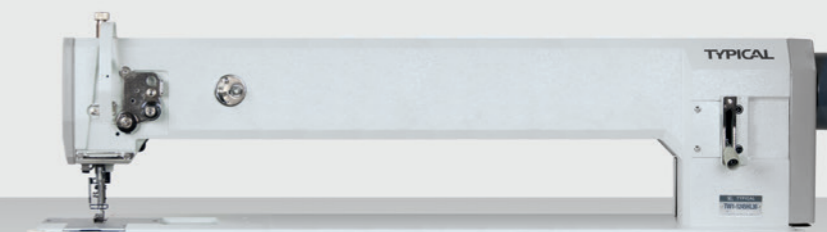

TYPICAL

TW1-1245